

Features

- Wide 5V to 48V Input Voltage Range
- Maximum Boost Output Up to 60V
- 0.22V FB adjustable LED drive current
- Directly drive 16 Series 1W/3W LED at VIN=24V
- Fixed 180KHz Switching Frequency
- Max. 5A Switching Current Capability
- Up to 94% efficiency
- Excellent line and load regulation
- EN PIN TTL shutdown capability
- Internal Optimize Power MOSFET
- Built in Soft-Start Function
- Built in Frequency Compensation
- Built in Thermal Shutdown Function
- Built in Current Limit Function
- Available in TO263-5L & TO220-5L package

Applications

- LED Lighting
- Boost constant current driver
- TFT LED Backlighting

General Description

The XL6006 regulator is fixed frequency PWM Boost (step-up) LED constant current driver, capable of driving Series 1W/3W/5W LED units with excellent line and load regulation. The regulator is simple to use because it includes internal frequency compensation and a fixed-frequency oscillator so that it requires a minimum number of external components to work.

The XL6006 could directly drive 16 Series 1W/3W LED units at VIN=24V .

The PWM control circuit is able to adjust the duty ratio linearly from 0 to 90%. An enable function, an over current protection function is built inside. An internal compensation block is built in to minimize external component count.

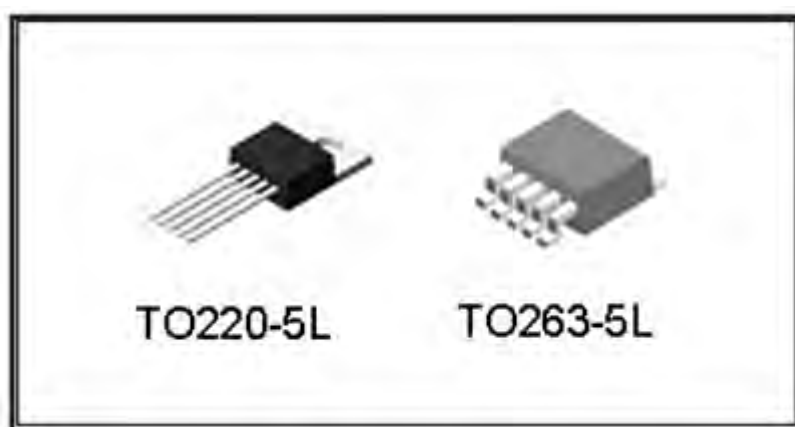

Figure1. Package Type of XL6006

Pin Configurations

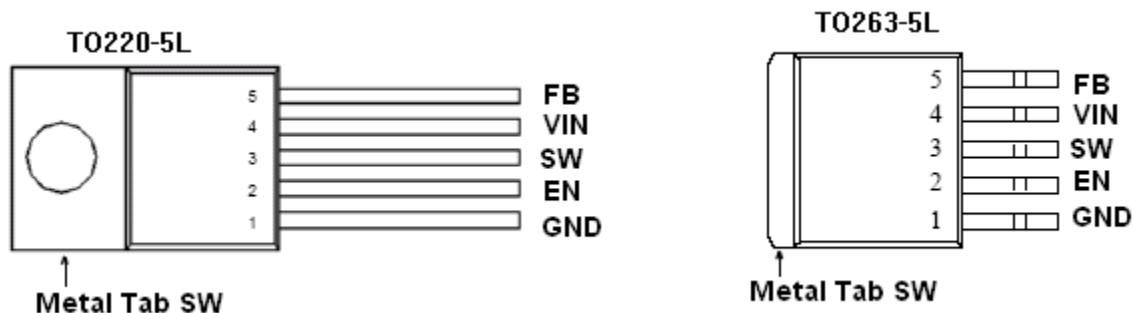

Figure2. Pin Configuration of XL6006 (Top View)

Table 1 Pin Description

Pin Number	Pin Name	Description
1	GND	Ground Pin.
2	EN	Enable Pin. Drive EN pin low to turn off the device, drive it high to turn it on. Floating is default high.
3	SW	Power Switch Output Pin (SW).
4	VIN	Supply Voltage Input Pin. XL6006 operates from a 5V to 48V DC voltage. Bypass Vin to GND with a suitably large capacitor to eliminate noise on the input.
5	FB	Feedback Pin (FB). The feedback threshold voltage is 0.22V.

Function Block

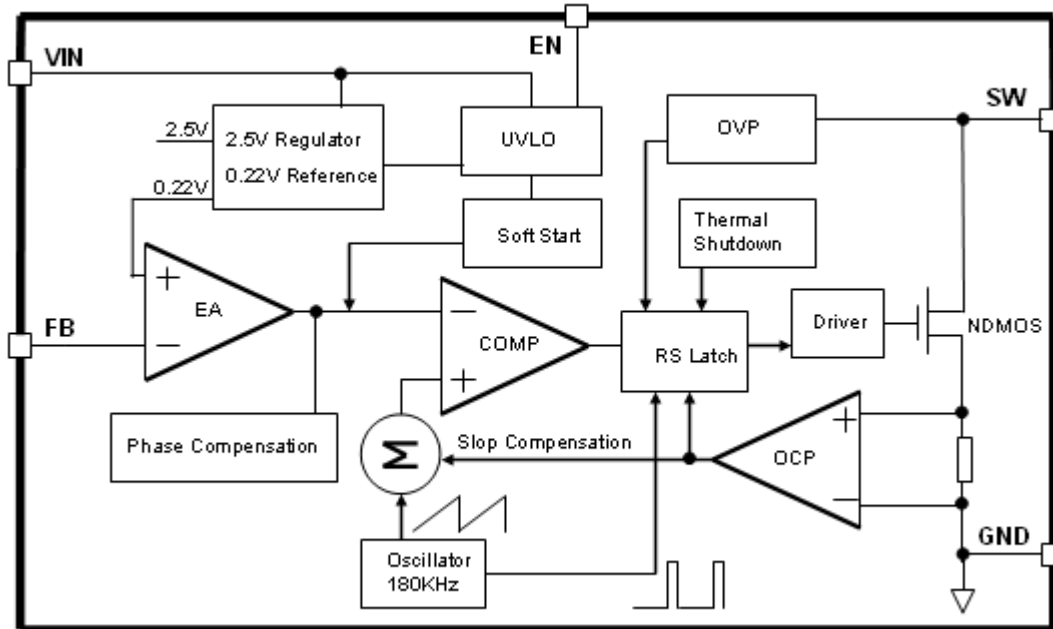

Figure3. Function Block Diagram of XL6006

Typical Application Circuit

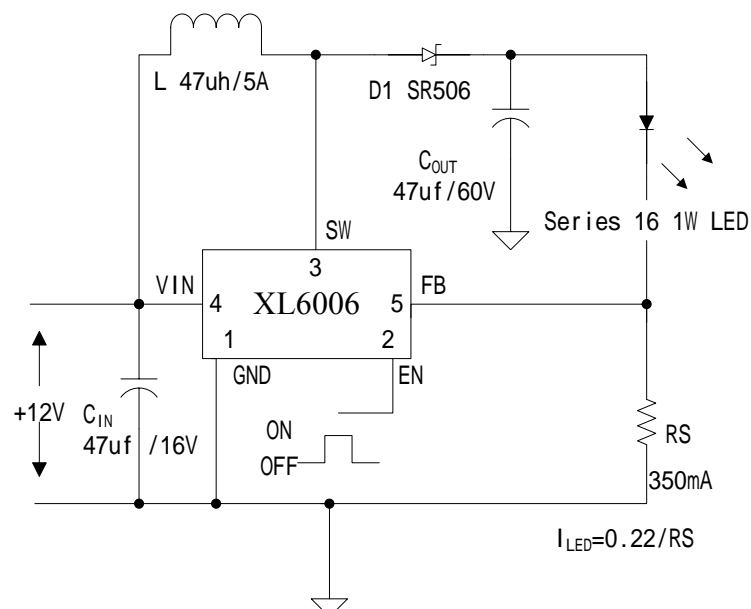

Figure4. XL6006 Typical Application Circuit

180KHz 60V 5A Switching Current Boost LED Constant Current Driver

XL6006

Ordering Information

Package	Temperature Range	Part Number	Marking ID	Packing Type
		Lead Free	Lead Free	
		XL6006TE1	XL6006TE1	Tube
		XL6006SE1	XL6006SE1	Tape & Reel

XLSEMI Pb-free products, as designated with “E1” suffix in the par number, are RoHS compliant.

Absolute Maximum Ratings (Note1)

Parameter	Symbol	Value	Unit
Input Voltage	V_{in}	-0.3 to 48	V
Feedback Pin Voltage	V_{FB}	-0.3 to V_{in}	V
EN Pin Voltage	V_{EN}	-0.3 to V_{in}	V
Output Switch Pin Voltage	V_{Output}	-0.3 to 60	V
Power Dissipation	P_D	Internally limited	mW
Thermal Resistance (TO220-5L/TO263-5L) (Junction to Ambient, No Heatsink, Free Air)	R_{JA}	30	°C/W
Operating Junction Temperature	T_J	-40 to 125	°C
Storage Temperature	T_{STG}	-65 to 150	°C
Lead Temperature (Soldering, 10 sec)	T_{LEAD}	260	°C
ESD (HBM)		2000	V

Note1: Stresses greater than those listed under Maximum Ratings may cause permanent damage to the device. This is a stress rating only and functional operation of the device at these or any other conditions above those indicated in the operation is not implied. Exposure to absolute maximum rating conditions for extended periods may affect reliability.

180KHz 60V 5A Switching Current Boost LED Constant Current Driver

XL6006

XL6006 Electrical Characteristics

$T_a = 25$; unless otherwise specified.

Symbol	Parameter	Test Condition	Min.	Typ.	Max.	Unit
<i>System parameters test circuit figure4</i>						
VFB	Feedback Voltage	$V_{in} = 5V \text{ to } 12V, V_{out}=24V$ $I_{load}=100mA$	209	220	231	mV
Efficiency	η	$V_{in}=12V, V_{out}=51.2V$ $I_{out}=350mA$	-	92	-	%

Electrical Characteristics (DC Parameters)

$V_{in} = 12V, GND=0V, V_{in}$ & GND parallel connect a 100uf/50V capacitor; $I_{out}=100mA, T_a = 25$; the others floating unless otherwise specified.

Parameters	Symbol	Test Condition	Min.	Typ.	Max.	Unit
Input operation voltage	V_{in}		5		48	V
Shutdown Supply Current	I_{STBY}	$V_{EN}=0V$		70	100	uA
Quiescent Supply Current	I_q	$V_{EN} = 2V,$ $V_{FB} = V_{in}$		2.5	5	mA
Oscillator Frequency	F_{osc}		144	180	216	KHz
Switch Current Limit	I_L	$V_{FB} = 0$		5		A
EN Pin Threshold	V_{EN}	High (Regulator ON) Low (Regulator OFF)		1.4 0.8		V
EN Pin Input Leakage Current	I_H	$V_{EN} = 2V$ (ON)		3	10	uA
	I_L	$V_{EN} = 0V$ (OFF)		3	10	uA
Max. Duty Cycle	D_{MAX}	$V_{FB}=0V$		90		%

180KHz 60V 5A Switching Current Boost LED Constant Current Driver

XL6006

Schottky Diode Selection Table

Current	Surface Mount	Through Hole	VR (The same as system maximum input voltage)				
			20V	30V	40V	50V	60V
1A			1N5817	1N5818	1N5819		
3A			1N5820	1N5821	1N5822		
			MBR320	MBR330	MBR340	MBR350	MBR360
			SK32	SK33	SK34	SK35	SK36
				30WQ03	30WQ04	30WQ05	
				31DQ03	31DQ04	31DQ05	
			SR302	SR303	SR304	SR305	SR306
5A			1N5823	1N5824	1N5825		
			SR502	SR503	SR504	SR505	SR506
			SB520	SB530	SB540	SB550	SB560
				50WQ03	50WQ04	50WQ05	

Typical System Application for VIN=12V to driver 16 x 1W series LED units

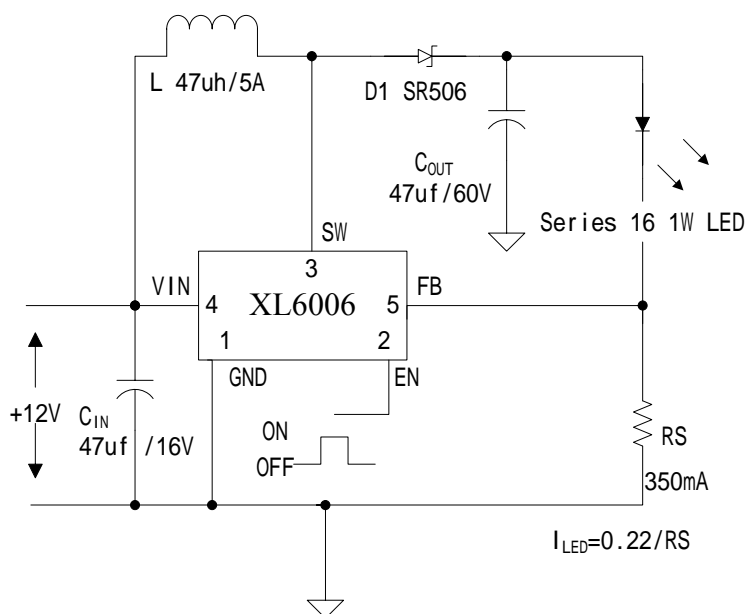

Figure5. XL6006 System Parameters Test Circuit (12V ~16 x 1W LED)

Typical System Application for VIN=12V to driver 8 x 3W series LED units

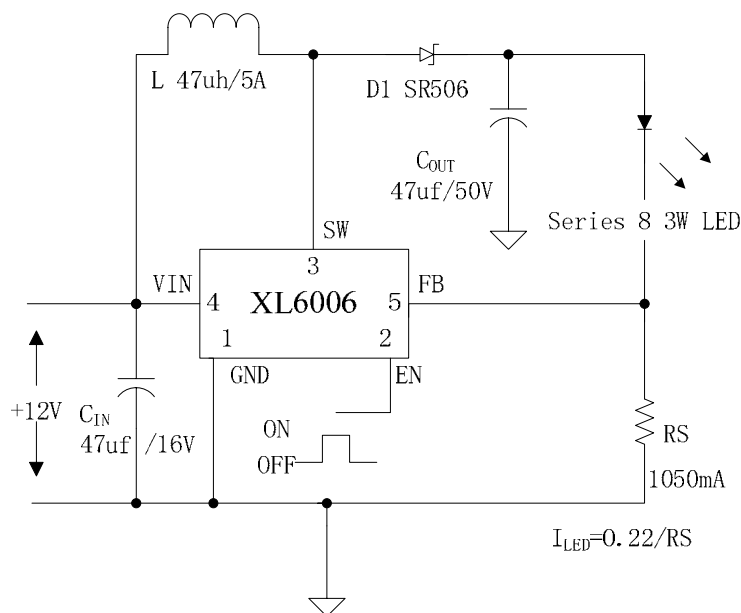

Figure6. XL6006 System Parameters Test Circuit (12V ~ 8 x 3W LED)

Typical System Application for VIN=24V to driver 16 x 3W series LED units

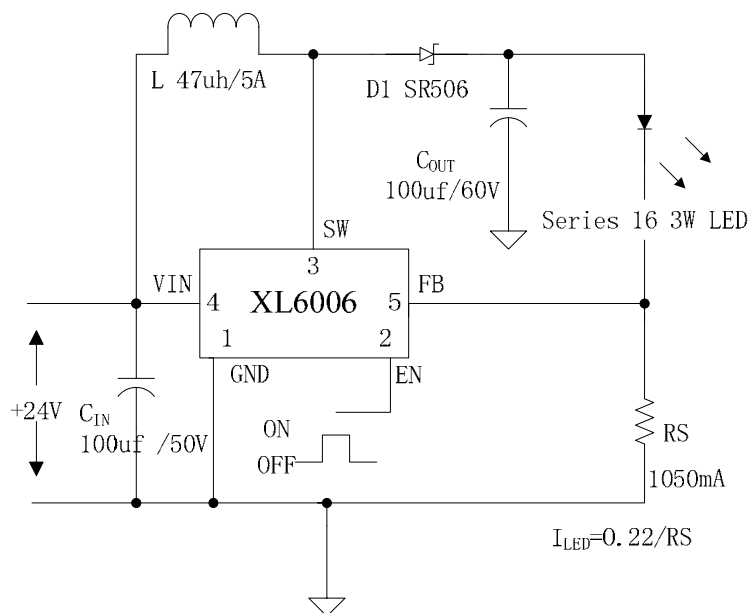

Figure7. XL6006 System Parameters Test Circuit (24V ~ 16 x 3W LED)

Typical System Application for VIN=12V to driver 16 series x 40 parallel White LED Array

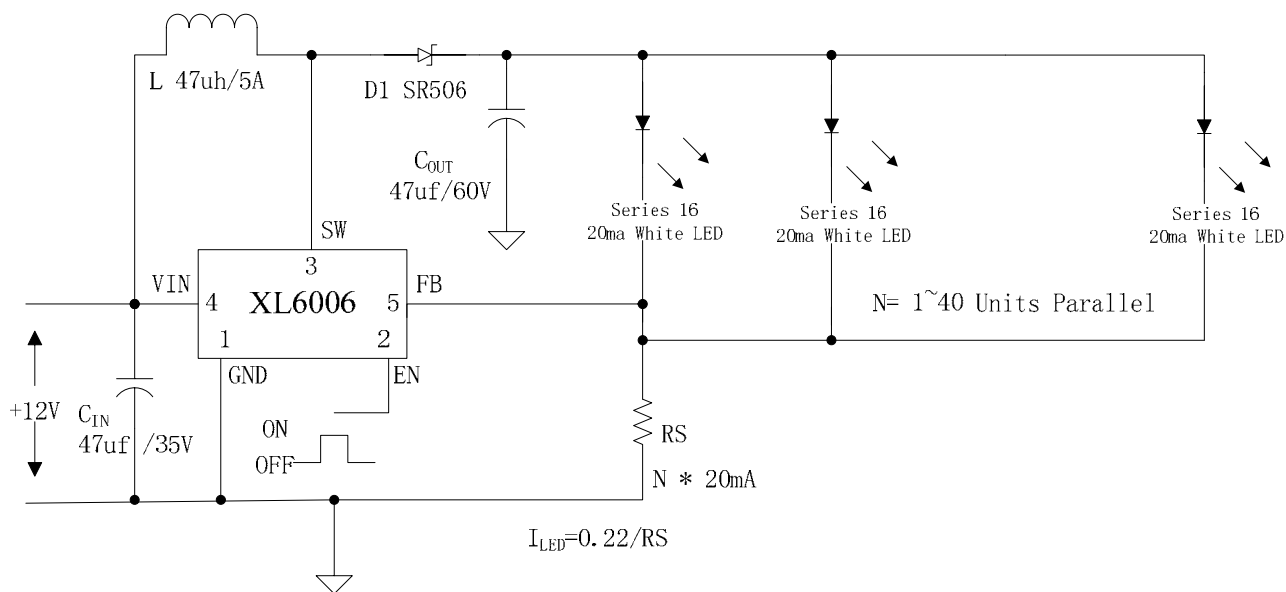

Figure8. XL6006 System Parameters Test Circuit (12V ~ 16 x 40 White LED)

Typical System Application for SEPIC Buck-Boost LED Driver

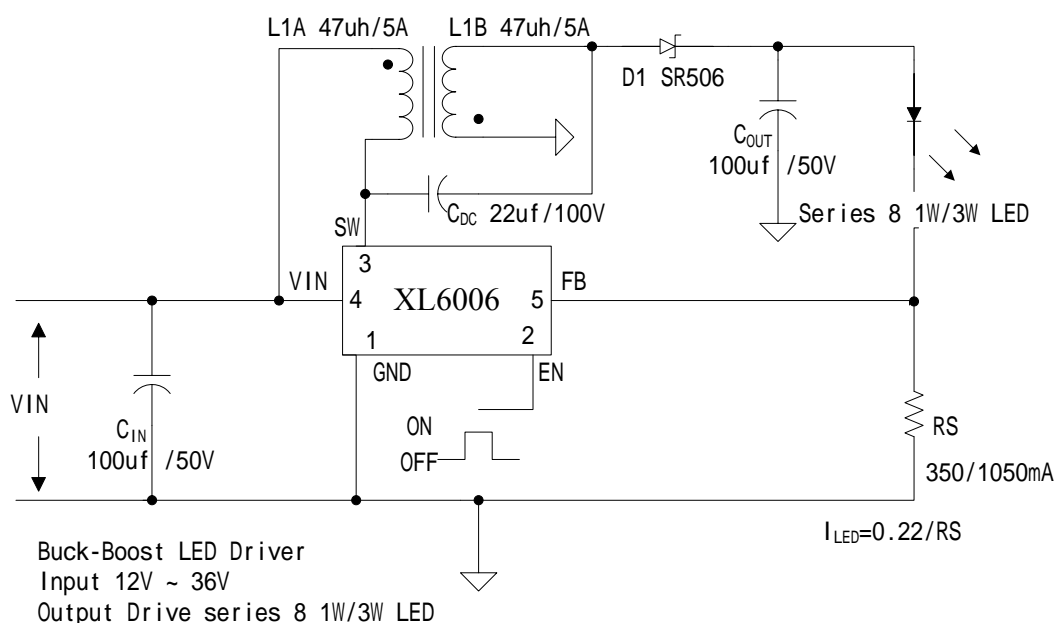

Figure9. XL6006 System Parameters Test Circuit (Buck-Boost LED Driver)

Typical System Application for VIN=12V to driver 16 x 1W series LED units With Dimming Function

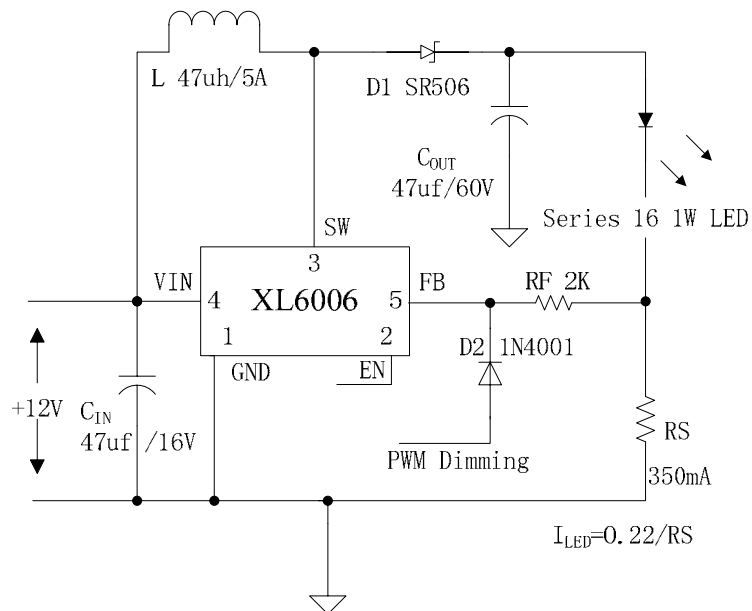
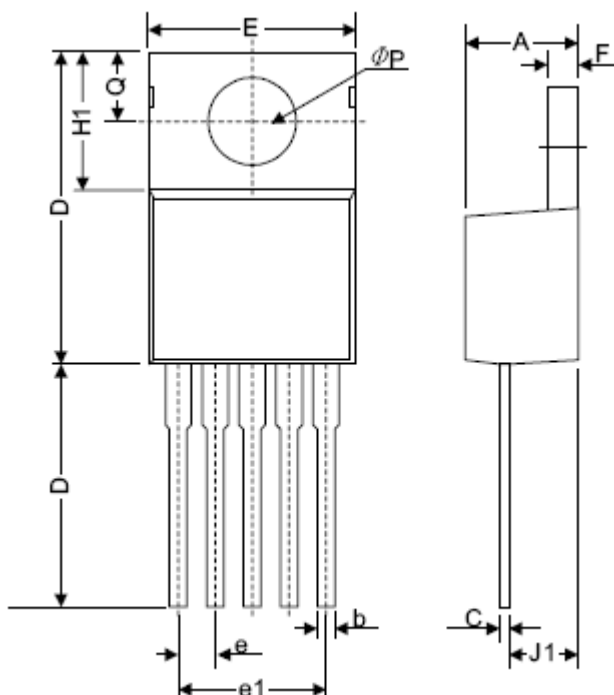

Figure10. XL6006 System Test Circuit (12V ~16 x 1W LED with Dimming Function)

Package Information

TO220-5L



Symbol	Dimensions In Millimeters		Dimensions In Inches	
	Min.	Max.	Min.	Max.
A	4.06	4.83	0.160	0.190
b	0.76	1.02	0.030	0.040
C	0.36	0.64	0.014	0.025
D	14.22	15.49	0.560	0.610
E	9.78	10.54	0.385	0.415
e	1.57	1.85	0.062	0.073
e(1)	6.68	6.93	0.263	0.273
F	1.14	1.40	0.045	0.055
H(1)	5.46	6.86	0.215	0.270
J(1)	2.29	3.18	0.090	0.125
L	13.21	14.73	0.520	0.580
ϕP	3.68	3.94	0.145	0.155
Q	2.54	2.92	0.100	0.115

Package Information

TO263-5L

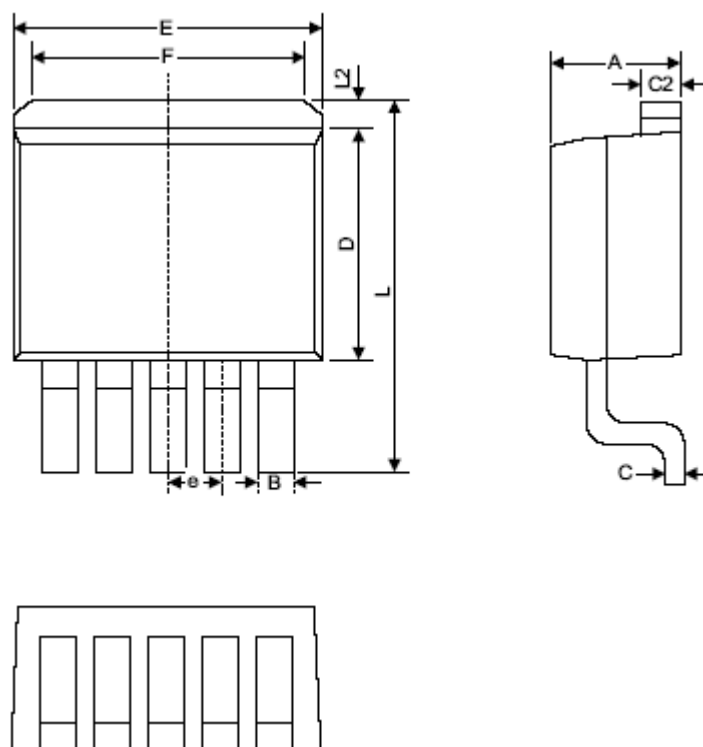

Symbol	Dimensions In Millimeters		Dimensions In Inches	
	Min.	Max.	Min.	Max.
A	4.06	4.83	0.160	0.190
B	0.76	1.02	0.030	0.040
C	0.36	0.64	0.014	0.025
C2	1.14	1.40	0.045	0.055
D	8.64	9.65	0.340	0.380
E	9.78	10.54	0.385	0.415
e	1.57	1.85	0.062	0.073
F	6.60	7.11	0.260	0.280
L	15.11	15.37	0.595	0.605
L2	-	1.40	-	0.055