

LOW VOLTAGE AUDIO POWER AMPLIFIER

DESCRIPTION

The UTC386 is a power amplifier designed for use in low voltage consumer applications. The gain is internally set to 20. Keep the external part count low, but the additional of external resistor and capacitor between pin 1 and pin 8 will increase the gain to any value up to 200.

FEATURES

- *Battery operation
- *Minimum external parts
- *Wide supply voltage range:4V~12V
- *Low quiescent current drain(4mA)
- *Voltage gains:20~200
- *Ground referenced input
- *Self-centering output quiescent voltage
- *low distortion

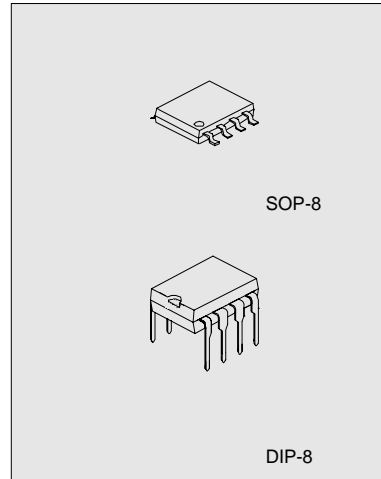

BLOCK DIAGRAM

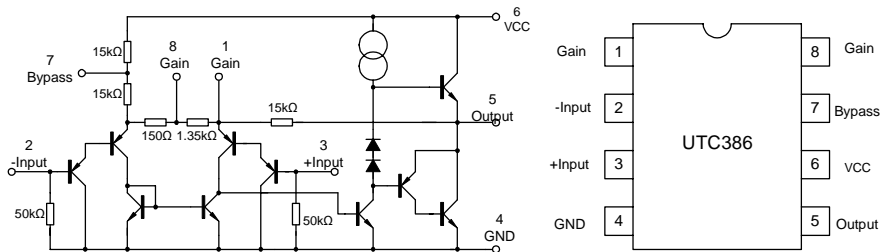

ABSOLUTE MAXIMUM RATINGS (Ta=25°C)

Characteristic	Symbol	Value	Unit
Supply Voltage	Vcc	15	V
Power Dissipation	Pd	660	mW
Input voltage	Vi	-0.4~+0.4	V
Operating Temperature	Topr	-20 to 70	°C
Storage Temperature	Tstg	-40 to 125	°C

ELECTRICAL CHARACTERISTICS

($V_{cc}=6V, f=1kHz, T_a=25^{\circ}C$, All voltage referenced to GND unless otherwise specified)

Characteristic	Symbol	Test Condition	Min	Typ.	Max	Unit
Quiescent circuit current	I _{CCQ}	V _i =0		4	8	mA
Output Power	P _o	V _{cc} =6V, R _L =8Ω, THD=10%	250	325		mW
		V _{cc} =9V, R _L =16Ω, THD=10%		500		mW
Voltage Gain	G _v	Pin1 and pin 8 open	24	26	28	dB
		10μF from pin 1 and pin 8	43	46	49	dB
Bandwidth	BW	Pin1 and pin 8 open		300		kHz
		10μF from pin 1 and pin 8		60		kHz
Total harmonic distortion	THD	V _{cc} =6V, R _L =8Ω, P _o =125mW, f=1kHz, pin1 and pin 8 open		0.2		%
Power supply Voltage Rejection Ratio	SVR	V _{cc} =6V, f=1kHz, C _{bypass} =10μF, pin1 and pin 8 open		30		dB
Input Resistance	R _i	Pin2 and pin 3 open		50		kΩ
Input Bias current	I _{BIAS}	Pin1 and pin 8 open		250		nA

TYPICAL APPLICATION CIRUIT

