

Features

- Output voltage tolerance $\leq \pm 3\%$ ($\pm 2\%$ up to 50 mA)
- 150 mA current capability
- Low-drop voltage
- Very low current consumption: 40 μA
- Overtemperature protection
- Short-circuit proof
- Suitable for use in automotive electronics
- Reverse polarity proof

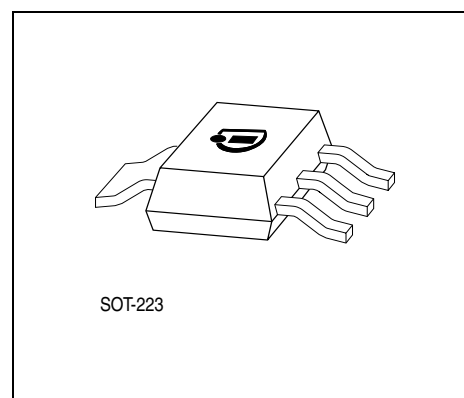

Type	Ordering Code	Package
TLE 4264-2 G	Q67006-A9483	P-SOT223-4-6 P-SOT223-4-4

Functional Description

The TLE 4264-2 is a monolithic integrated low-drop fixed voltage regulator which can supply loads up to 150 mA. It is functional compatible to the TLE 4264, but has a reduced quiescent current of typ. 40 μA . The TLE 4264-2 is especially designed for all applications which require very low quiescent currents. The device is available in the small surface mounted P-SOT223-4-1 package. The device is pin compatible to the TLE 4264. The regulator is designed to supply microprocessor systems under the severe condition of automotive applications and is therefore equipped with additional protection against overload, short-circuit and overtemperature. Of course the TLE 4264-2 can be used in all other applications, wherever a stabilized voltage is required.

An input voltage V_i in the range of $5.5 \text{ V} < V_i < 45 \text{ V}$ is regulated to $V_{Q,nom} = 5 \text{ V}$ with an accuracy of $\pm 3\%$. An accuracy of $\pm 2\%$ is kept for a load current range up to 50 mA.

The device operates in the temperature range of $T_j = -40$ to $150 \text{ }^\circ\text{C}$.

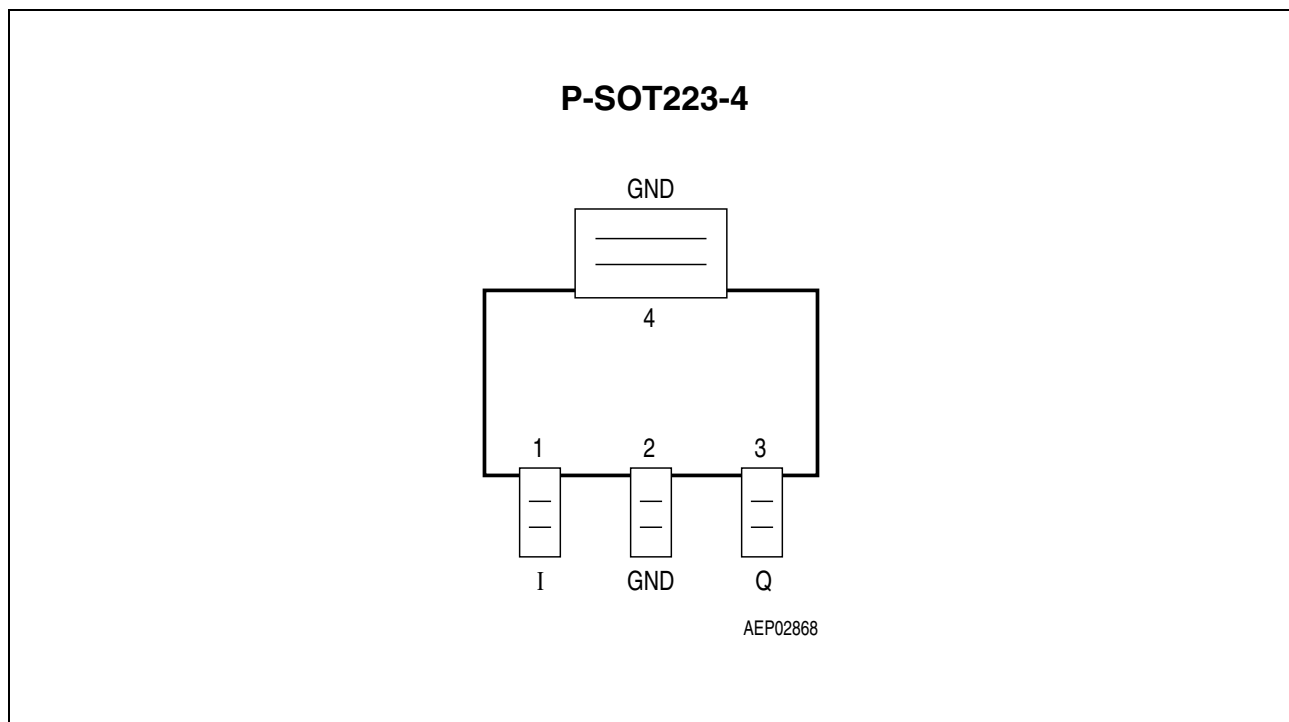

Figure 1 Pin Configuration (top view)

Pin Definitions and Functions

Pin	Symbol	Function
1	I	Input voltage; block to ground directly with a ceramic capacitor
2, 4	GND	Ground
3	Q	5-V output voltage; block to ground with a capacitor $C_Q \geq 10 \mu\text{F}$, $\text{ESR} \leq 4 \Omega$

Figure 2 Pin Configuration (top view) (cont'd)

Circuit Description

The control amplifier compares a reference voltage, which is kept highly precise by resistance adjustment, to a voltage that is proportional to the output voltage and drives the base of the series transistor via a buffer. Saturation control, working as a function of load current, prevents any over-saturation of the power element. The IC is additionally protected against overload, overtemperature and reverse polarity.

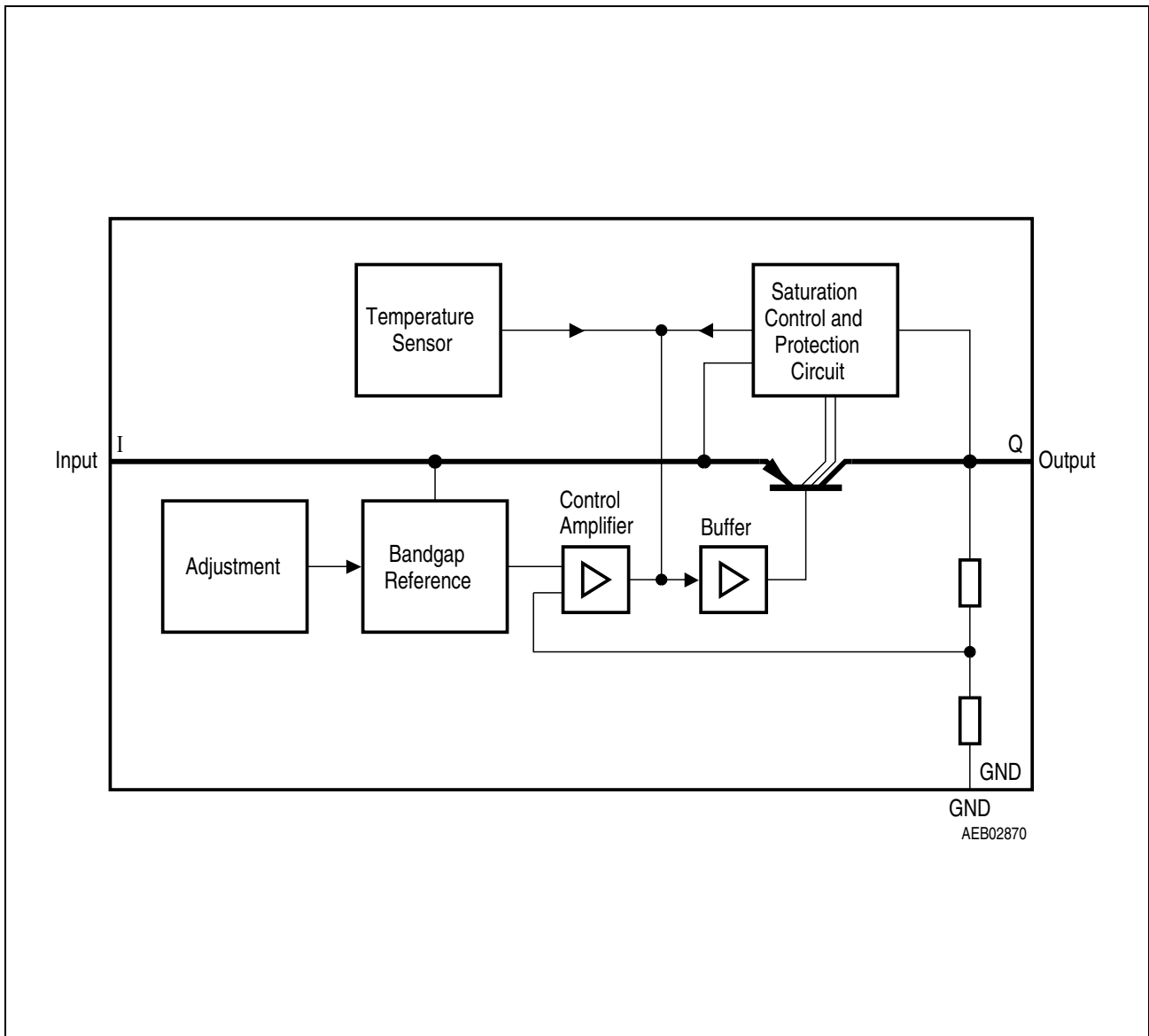

Figure 3 Block Diagram

Absolute Maximum Ratings

Parameter	Symbol	Limit Values		Unit	Notes
		min.	max.		

Input I

Input voltage	V_I	- 42	45	V	-
Input current	I_I	-	-	-	limited internally

Output Q

Output voltage	V_Q	- 0.3	32	V	-
Output current	I_Q	-	-	-	limited internally

Ground GND

Current	I_{GND}	50	-	mA	-
---------	-----------	----	---	----	---

Absolute Maximum Ratings

Temperatures

Junction temperature	T_j	–	150	°C	–
Storage temperature	T_{stg}	– 50	150	°C	–

Thermal Resistances

Junction-ambient	R_{thj-a}	–	164	K/W	P-SOT223-4-6 ¹⁾
	R_{thj-a}	–	81	K/W	P-SOT223-4-6, 300 mm ² heat sink area
Junction-pin	R_{thj-p}	–	17	K/W	P-SOT223-4-6 ²⁾

Operating Range

Input voltage	V_i	5.5	45	V	–
Junction temperature	T_j	– 40	150	°C	–

1) Package mounted on PCB 80 × 80 × 1.5mm³; 35μ Cu; 5μ Sn; Footprint only; zero airflow.

2) Measured to pin 4.

Characteristics
 $V_I = 13.5 \text{ V}; -40 \text{ }^\circ\text{C} \leq T_j \leq 125 \text{ }^\circ\text{C}$, unless specified otherwise

Parameter	Symbol	Limit Values			Unit	Test Conditions
		min.	typ.	max.		
Output voltage	V_Q	4.85	5.0	5.15	V	$5 \text{ mA} \leq I_Q \leq 100 \text{ mA}$ $6 \text{ V} \leq V_I \leq 21 \text{ V}$
Output voltage	V_Q	4.9	5.0	5.1	V	$5 \text{ mA} \leq I_Q \leq 50 \text{ mA}$ $9 \text{ V} \leq V_I \leq 16 \text{ V}$
Output-current limiting	I_Q	150	200	500	mA	–
Current consumption $I_q = I_I - I_Q$	I_q	–	40	60	μA	$I_Q = 100 \mu\text{A}$, $T_j \leq 85 \text{ }^\circ\text{C}$
		–	40	70	μA	$I_Q = 100 \mu\text{A}$,
Current consumption $I_q = I_I - I_Q$	I_q	–	1.7	4	mA	$I_Q = 50 \text{ mA}$
Drop voltage	V_{dr}	–	0.22	0.5	V	$I_Q = 100 \text{ mA}^1)$
Load regulation	$\Delta V_{Q,lo}$	–	50	90	mV	$I_Q = 1 \text{ to } 100 \text{ mA}$ $V_I = 13.5 \text{ V}$
Line regulation	$\Delta V_{Q,li}$	–	5	30	mV	$V_I = 6 \text{ to } 28 \text{ V}$ $I_Q = 1 \text{ mA}$
Power Supply Ripple Rejection	$PSRR$	–	68	–	dB	$f_r = 100 \text{ Hz}$ $V_r = 0.5 V_{PP}$
Output Capacitor	C_Q	10	–	–	μF	$ESR \leq 4 \Omega$ at 10kHz

¹⁾ Drop voltage = $V_I - V_Q$ (measured where V_Q has dropped 100 mV from the nominal value obtained at $V_I = 13.5 \text{ V}$)

Application Information

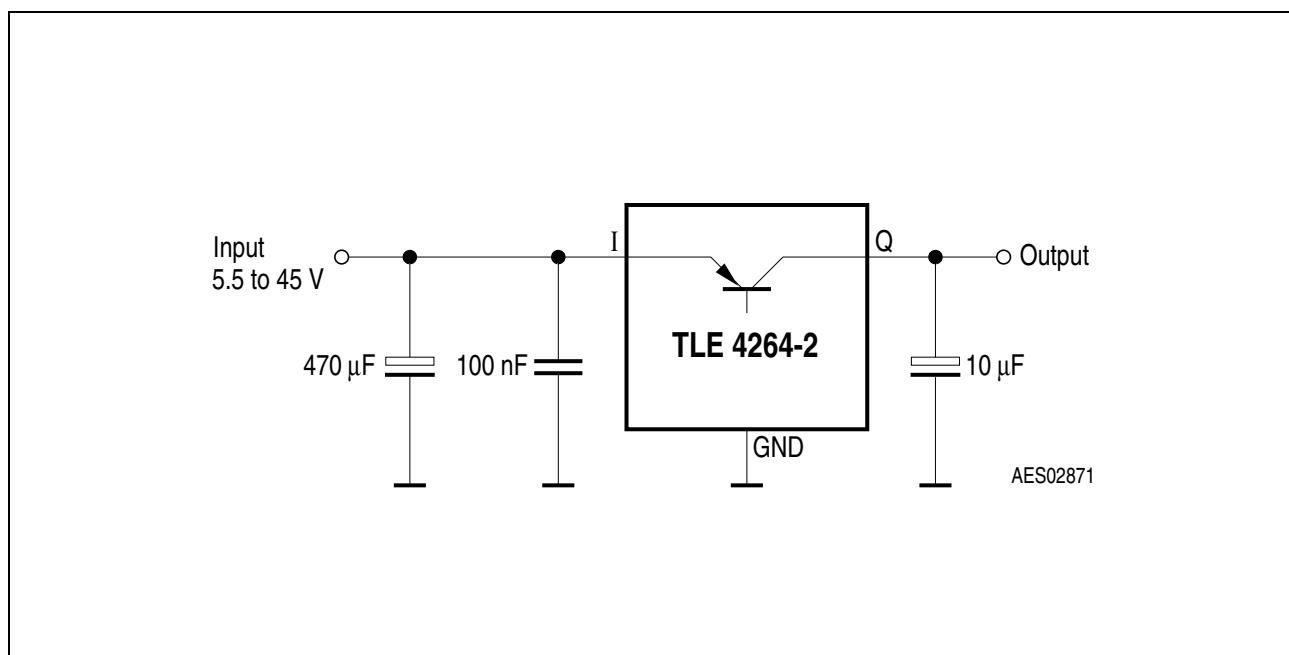

Figure 4 Application Circuit

In the TLE 4264-2 the output voltage is divided and compared to an internal reference of 2.5 V typical. The regulation loop controls the output to achieve an output voltage of 5 V with an accuracy of $\pm 3\%$ at an input voltage range of $5.5\text{ V} < V_i < 45\text{ V}$.

Fig. 4 shows a typical application circuit. For stability of the control loop the TLE 4264-2 output requires an output capacitor C_o of at least 10 μF with a maximum permissible ESR of 4 Ω . Tantalum as well as multi layer ceramic capacitors are suitable.

At the input of the regulator an input capacitor is necessary for compensating line influences (100 nF ceramic capacitor recommended). A resistor of approx. 1 Ω in series with C_i , can damp any oscillation occurring due the input inductivity and the input capacitor.

In the application circuit shown in Fig. 4 an additional electrolytic input capacitor of 470 μF is added in order to buffer supply line influences. This capacitor is recommended, if the device is sourced via long supply lines of several meters.

The TLE 4264-2 can supply up to 150 mA. However for protection for high input voltage above 25 V, the output current is reduced (SOA protection).

Typical Performance Characteristics

Output Voltage V_Q versus Temperature T_i

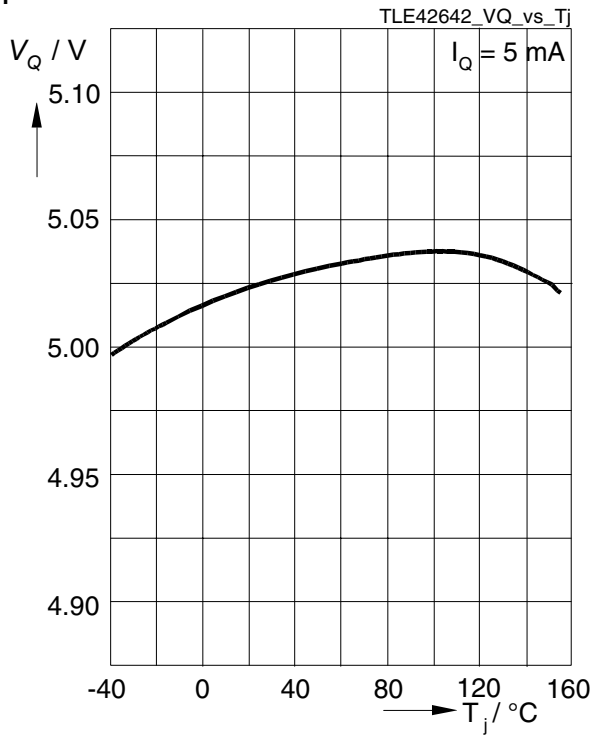

Drop Voltage V_{dr} versus Output Current I_Q

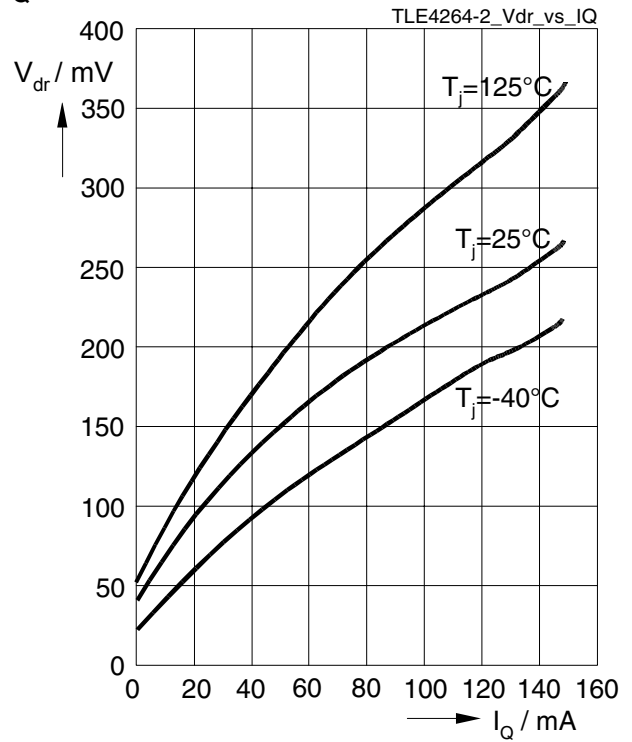

Output Voltage V_Q versus Input Voltage V_i

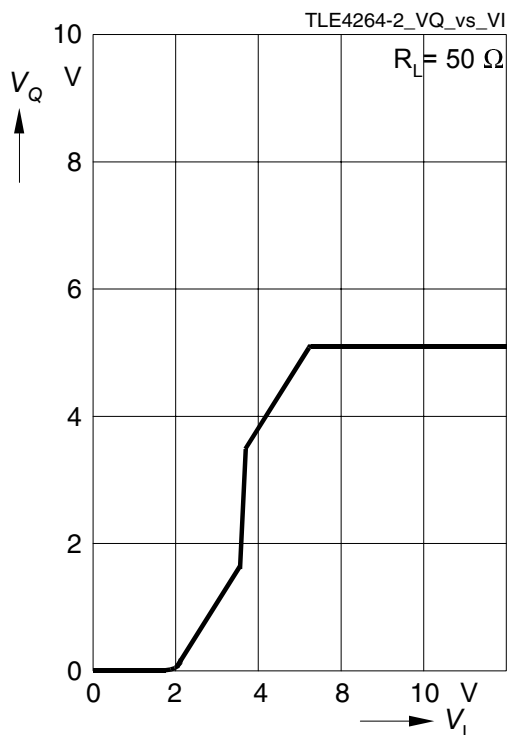

Current Consumption I_q versus Output Current I_Q

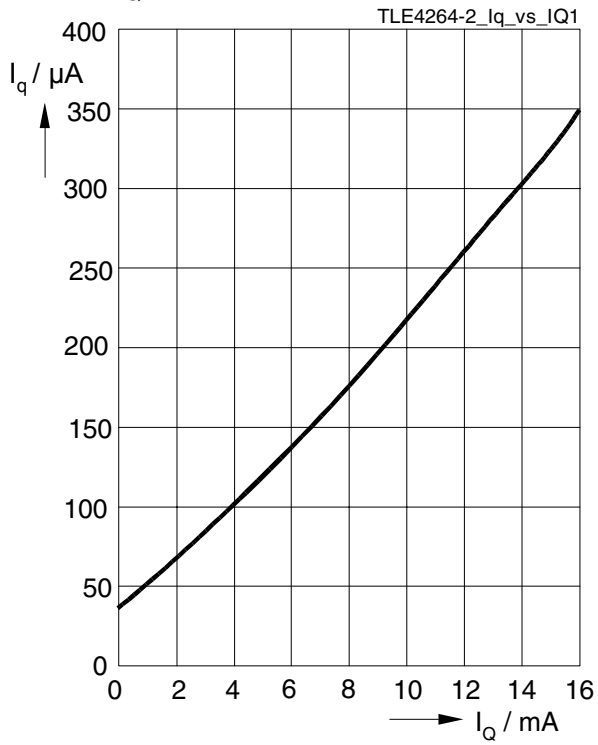

Current Consumption I_q versus Output Current I_Q

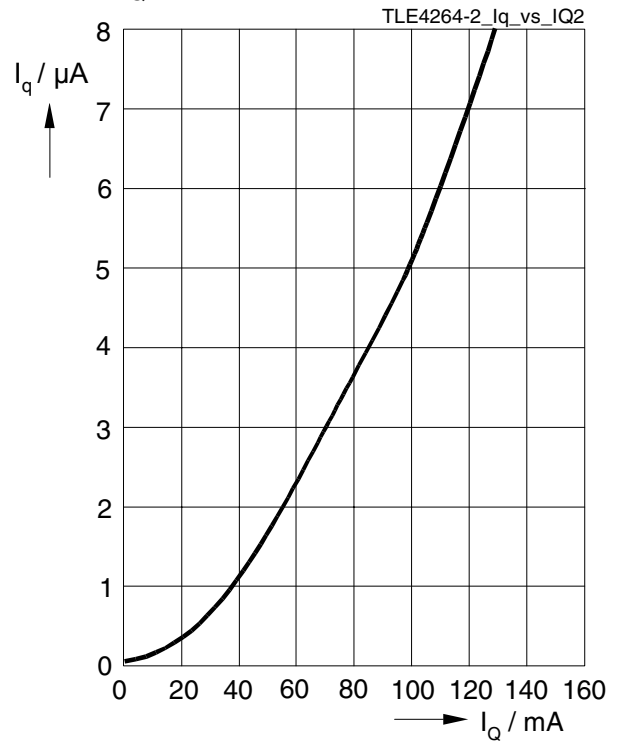

Package Outlines

P-SOT223-4-6 (Plastic Small Outline Transistor)

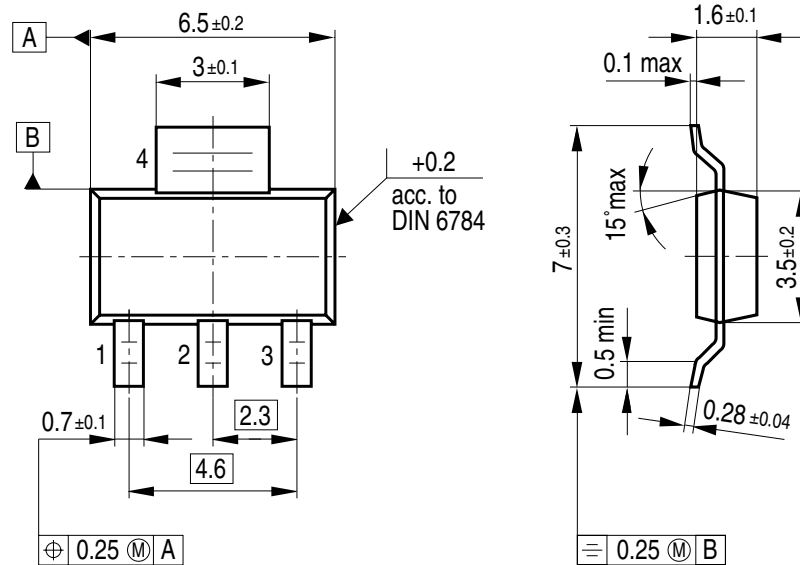

Weight approx. 0.15 g

GPS05560

Sorts of Packing

Package outlines for tubes, trays etc. are contained in our Data Book "Package Information"

SMD = Surface Mounted Device

Dimensions in mm

Package Outlines

P-SOT223-4-4
(Plastic Small Outline Transistor)

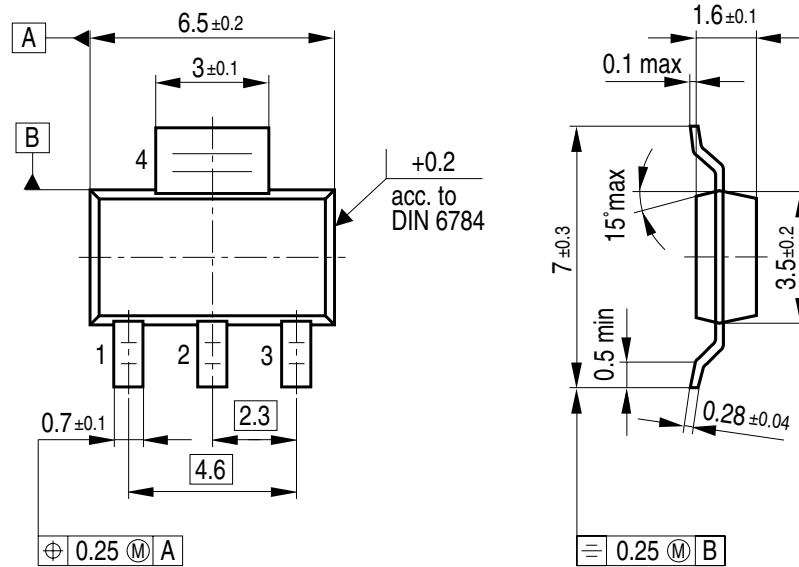

Weight approx. 0.15 g

GPS05560

Sorts of Packing

Package outlines for tubes, trays etc. are contained in our Data Book "Package Information"

SMD = Surface Mounted Device

Dimensions in mm

Edition 2002-12-21

**Published by Infineon Technologies AG,
St.-Martin-Strasse 53,
D-81541 München, Germany**

**© Infineon Technologies AG 2002.
All Rights Reserved.**

Attention please!

The information herein is given to describe certain components and shall not be considered as warranted characteristics.

Terms of delivery and rights to technical change reserved.

We hereby disclaim any and all warranties, including but not limited to warranties of non-infringement, regarding circuits, descriptions and charts stated herein.

Infineon Technologies is an approved CECC manufacturer.

Information

For further information on technology, delivery terms and conditions and prices please contact your nearest Infineon Technologies Office in Germany or our Infineon Technologies Representatives worldwide (see address list).

Warnings

Due to technical requirements components may contain dangerous substances. For information on the types in question please contact your nearest Infineon Technologies Office.

Infineon Technologies Components may only be used in life-support devices or systems with the express written approval of Infineon Technologies, if a failure of such components can reasonably be expected to cause the failure of that life-support device or system, or to affect the safety or effectiveness of that device or system. Life support devices or systems are intended to be implanted in the human body, or to support and/or maintain and sustain and/or protect human life. If they fail, it is reasonable to assume that the health of the user or other persons may be endangered.