

SE9020C/D

Standalone Linear Lithium Battery Charger

Description

SE9020C/D is a complete Limit-current & constant voltage charger for single cell Lithium-ion and Lithium-Polymer batteries. Its SOT-23-6L package and low external component count make SE9020C/D ideally suited for portable applications. Furthermore, the SE9020C/D is specifically designed to work within Universal Travel Charger.

SE9020C/D has a built-in detector that will automatically detect the polarity of the inserted battery and charge the battery at the correct the polarity. The charge voltage is fixed at 4.2V. The SE9020C/D automatically terminates the charge cycle when the charge current drops to 14mA after the final float voltage is reached.

When the input supply is removed, the SE9020C/D automatically enters a low current stage, dropping the battery drain current to less than 7mA. The SE9020C/D can be put into shutdown mode, reducing the supply current to 30uA.

SE9020C/D supports two LED drivers that give the customers the option to select which method fit best in their respective applications. One LED driver is internally set to indicate the power on/off of the IC. Another LED driver can either drive a standard LED named SE9020D or 7-color LED named SE9020C, which will be explained in detail in the application notes.

Application

- Universal Travel Charger

Pin Configuration

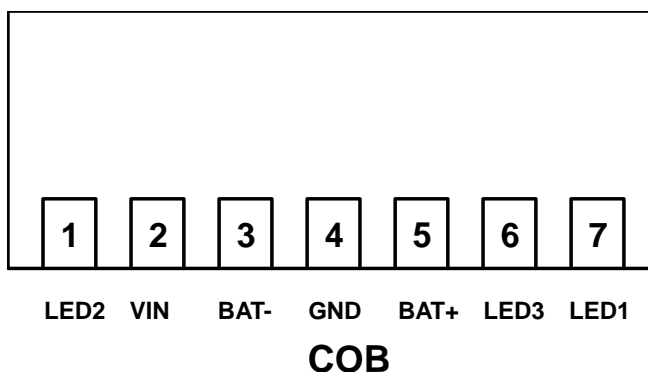

Features

- Automatically Identifies the polarity of the battery
- Typical-Current to 250mA
- Short-Circuit Protection
- Low external component
- Build in high precision reference voltage
- Preset 4.2V Charge Voltage with $\pm 1\%$ Accuracy.
- 20uA Supply Current in Shutdown.
- Support Standalone Battery Charger.
- Support both 2-LED and Flashing LED schemes.
- Available in 6-Lead SOT-23-6L DIP-8 and COB Packages.
- RoHS Compliant and 100% Lead (Pb)-Free

Pin Configuration

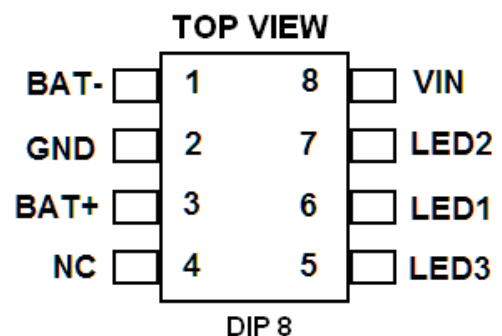
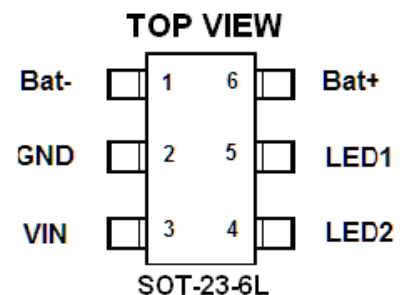

Application Diagram

Figure 1 7 color LED circuit

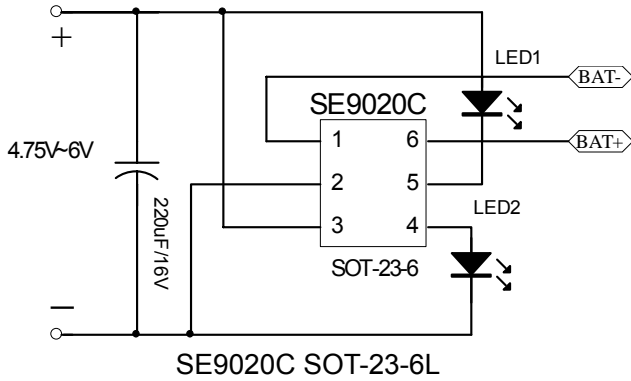

Figure 2 2 LED circuit

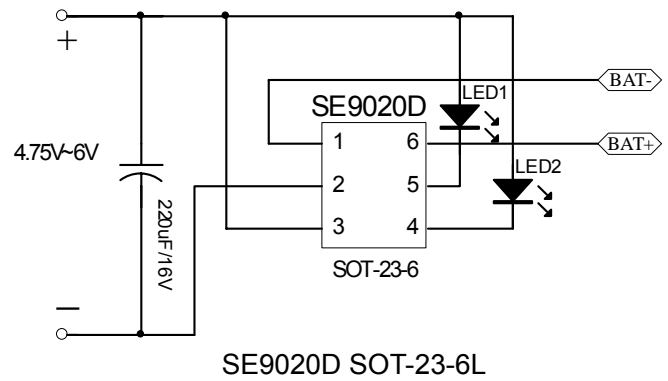

Figure 3 7 color LED circuit

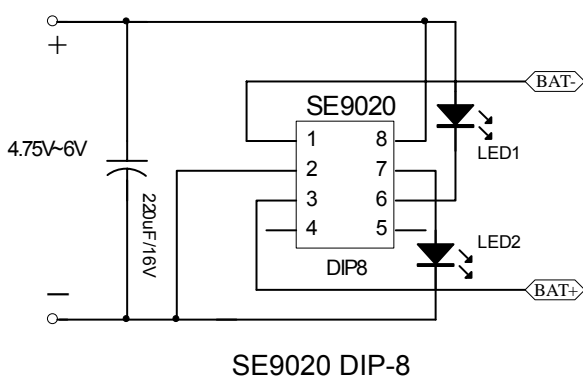

Figure 4 2 LED circuit

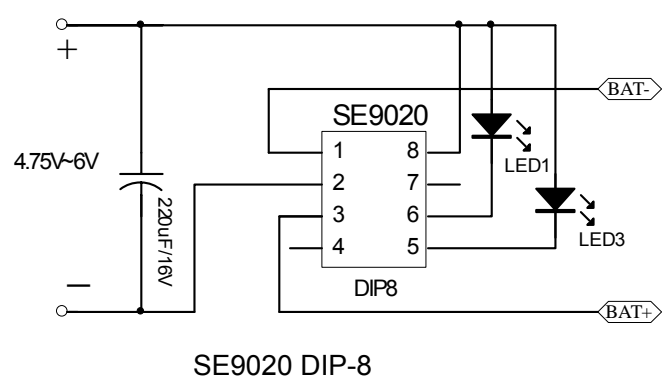

Figure 5 7 color LED circuit

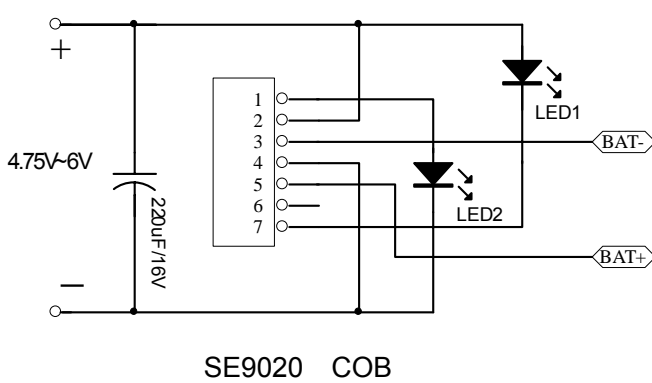
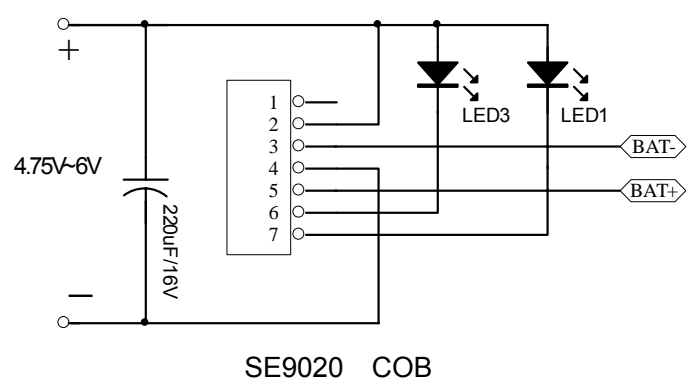

Figure 6 2 LED circuit



Absolute Maximum Rating ⁽¹⁾

Parameter	Symbol	Value	Units
Input Supply Voltage	V_{in}	8	V
BAT Voltage	V_{BAT+}	7	V
BAT Voltage	V_{BAT-}	7	V
LED1	V_{LED1}	7	V
LED2	V_{LED2}	7	V
BAT Short-Circuit Duration		Continuous	
Thermal Resistance, Junction-to-Ambient	Θ_{JA}	250 (SOT-23-6)	°C/W
BAT Pin Current	I_{BAT}	250	mA
LED1/2 Current	I_{LED}	20	mA
Maximum Junction Temperature	T_J	125	°C
Storage Temperature	T_S	-65 to +125	°C
Lead Temperature (Soldering, 10 sec)		300	°C

Operating Rating ⁽²⁾

Parameter	Symbol	Value	Units
Supply Input Voltage	V_{IN}	+4.75 to +6	V
Junction Temperature	T_J	-40 to +85	°C

Electrical Characteristics

$V_{IN} = 5V$; $T_J = 25^\circ C$; unless otherwise specified.

Symbol	Parameter	Conditions	Min	Typ	Max	Unit
V_{in}	Input Supply Voltage		4.75		6	V
V_{Term}	Regulated Output (Terminal) Voltage	$V_{in}=6V$, $I_{BAT} = 14mA$.	4.158	4.2	4.242	V
V_{Float}	Floating Voltage	$V_{in}=6V$, $I_{BAT} = 0$. Note #1.		V_{in}		V
I_{BAT}	BAT Pin Current	$V_{in}=6V$, $ V_{btp}-V_{btn} <3.5V$		250		mA
V_{Short}	Short Circuit Protection Voltage	$V_{in}=6V$, $ V_{btp}-V_{btn} :3V \text{ to } 0V$		2.5		V
F_{OSC}	Flashing Frequency	$V_{in}=6V$, $ V_{btp}-V_{btn} =3.5V$		5		Hz

Notes:

#1. When the battery disconnected to the charger, SE9020 disables the internal charging transistor. This will cause the V_{bat} to float to V_{in} .

SE9020C/D

Standalone Linear Lithium Battery Charger

Pin Functions

Pin	Pin Function Description	Pin	Pin Function Description
Vin	Positive Input Supply Voltage. Provides power to the charger. Vin can range from 4.75V to 6V and should be bypassed with at least a 1 μ F capacitor.	BAT-	Charge Current Output. Provides charge current to the battery and regulates the final float voltage to 4.2V. SE9020C/D will automatically identify the polarity so this pin can be connected to BAT+ also.
GND	Ground.	LED1	LED1 is lit on when the Vin is connected to any voltage between 4.75V and 6V.
BAT+	Charge Current Output. Provides charge current to the battery and regulates the final float voltage to 4.2V. SE9020C/D will automatically identify the polarity so this pin can be connected to BAT- also.	LED2	With SOT-23-6L package. LED2 supports 2 options to indicate the Charging and Full of the battery. With SE9020D, the LED2 will flash at 5Hz frequency during charging. When the battery is full, LED2 will output a constant voltage and the flashing will stop. With SE9020C, LED2 can drive a standard 7-color IC-LED. With DIP-8 package LED2 can only drive a standard 7-color IC-LED.
LED3	With DIP-8 package the LED3 will flash at 5Hz frequency during charging. When the battery is full, LED3 will output a constant voltage and the flashing will stop	NC	With DIP-8 package NC is the unused PIN

Typical Operating Characteristics

I_{charge} Versus Vin

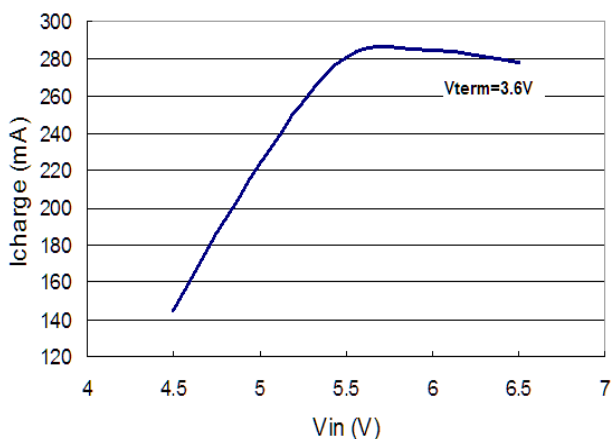

V_{term} Versus Vin

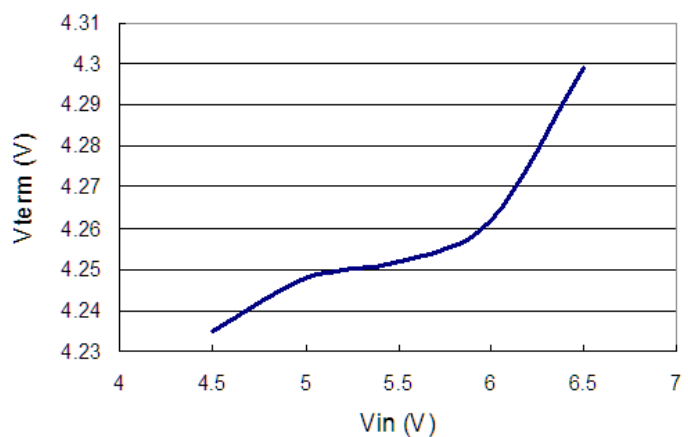

Typical Operating Characteristics

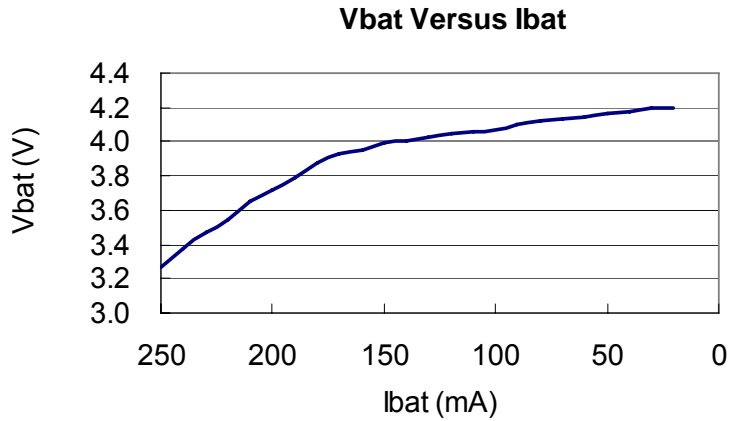

Application Notes:

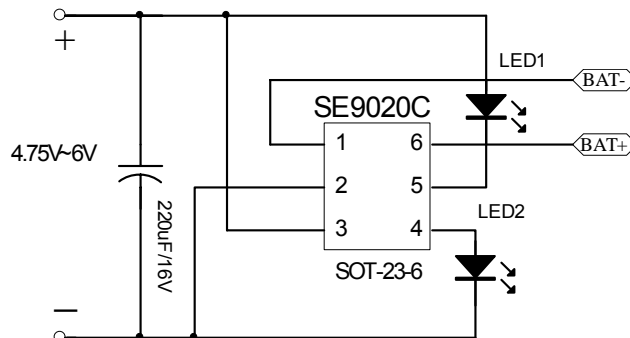

Figure #5. Flashing 7-Color LED Application. SE9020C also supports 7-color LED applications. The connections are shown in this schematic and the Logic of LED's is shown in the table below.

Detection Description	Power Supply Condition	Battery Condition	LED1	LED2 (7-color)
Battery Detection	Disconnected	Connected	Bright	Dark
	Connected	Disconnected	Bright	Dark
Battery Unload	Connected	Disconnected	Bright	Dark
Battery Charge		Connected	Bright	Flash
Battery Full			Bright	Dark
Battery Shorted		Shorted	Dark	Dark

Application Notes:

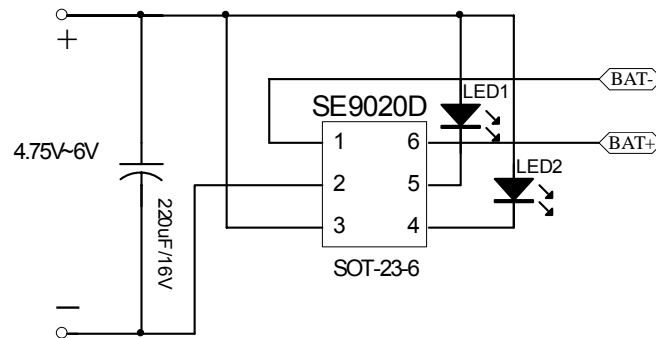
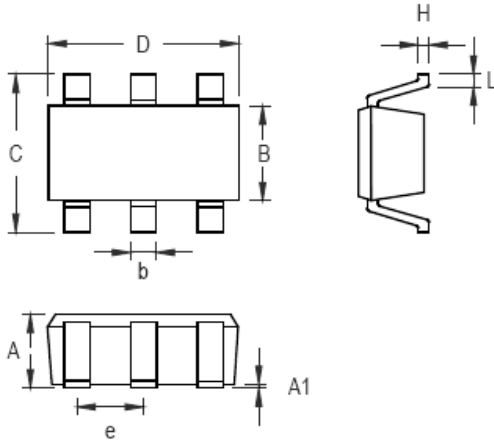

Figure #6. Flashing 2-LED Application. The LED's are connected between Pin1 and Pin6 to Power Supply. The logic of LED's operations is shown in the table below.

Detection Description	Power Supply Condition	Battery Condition	LED1	LED2
Battery Detection	Disconnected	Connected	Bright	Dark
	Connected	Disconnected	Bright	Dark
Battery Unload	Connected	Disconnected	Bright	Dark
Battery Charge		Connected	Bright	Flash
Battery Full			Bright	Bright
Battery Shorted		Shorted	Dark	Dark

OUTLINE DRAWING SOT-23-6L



Symbol	Dimensions In Millimeters		Dimensions In Inches	
	Min	Max	Min	Max
A	0.889	1.295	0.031	0.051
A1	0.000	0.152	0.000	0.006
B	1.397	1.803	0.055	0.071
b	0.250	0.560	0.010	0.022
C	2.591	2.997	0.102	0.118
D	2.692	3.099	0.106	0.122
e	0.838	1.041	0.033	0.041
H	0.080	0.254	0.003	0.010
L	0.300	0.610	0.012	0.024

OUTLINE DRAWING DIP-8

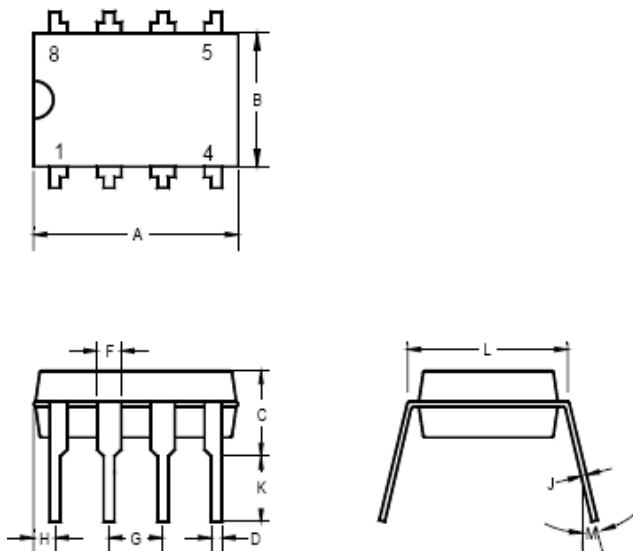

	INCHES			MILLIMETERS		
	MIN	TYP	MAX	MIN	TYP	MAX
A	0.355	0.365	0.400	9.02	9.27	10.16
B	0.240	0.250	0.280	6.10	6.35	7.11
C	-	-	0.210	-	-	5.33
D	-	0.018	-	-	0.46	-
F	-	0.060	-	-	1.52	-
G	-	0.100	-	-	2.54	-
H	0.050	-	0.090	1.27	-	2.29
J	0.008	-	0.015	0.20	-	0.38
K	0.115	0.130	0.150	2.92	3.30	3.81
L	0.300 BSC.			7.62 BSC.		
M	-	7°	15°	-	7°	15°