

Features

- 60V/200A
 $R_{DS(ON)}=2.8\text{ m}\Omega(\text{Typ.}) @ V_{GS}=10\text{V}$
- Avalanche Rated
- Reliable and Rugged
- Lead Free and Green Devices Available

Applications

- Automotive applications and a wide variety of other applications
- High Efficiency Synchronous in SMPS
- High Speed Power Switching

Pin Description

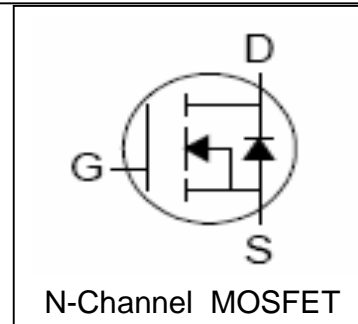
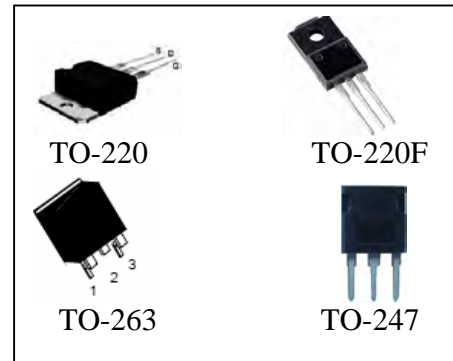

Absolute Maximum Ratings

Symbol	Parameter	Rating	Unit
Common Ratings ($T_A=25^\circ\text{C}$ Unless Otherwise Noted)			
V_{DSS}	Drain-Source Voltage	60	V
V_{GSS}	Gate-Source Voltage	± 25	
T_J	Maximum Junction Temperature	175	$^\circ\text{C}$
T_{STG}	Storage Temperature Range	-55 to 175	$^\circ\text{C}$
I_S	Diode Continuous Forward Current	$T_C=25^\circ\text{C}$ 200	A
Mounted on Large Heat Sink			
I_{DP}	300 μs Pulsed Drain Current Tested	$T_C=25^\circ\text{C}$ 800 ^①	A
I_D	Continue Drain Current	$T_C=25^\circ\text{C}$ 200 ^②	
		$T_C=100^\circ\text{C}$ 140	
P_D	Maximum Power Dissipation	$T_C=25^\circ\text{C}$ 380	W
		$T_C=100^\circ\text{C}$ 220	
$R_{\theta JC}$	Thermal Resistance -Junction to Case	0.45	$^\circ\text{C}/\text{W}$
$R_{\theta JA}$	Thermal Resistance-Junction to Ambient	62.5	
Drain-Source Avalanche Ratings			
E_{AS}	Avalanche Energy ,Single Pulsed	1500	mJ

Electrical Characteristics ($T_A=25^{\circ}\text{C}$ Unless Otherwise Noted)

Symbol	Parameter	Test Condition	RU6199			Unit
			Min.	Typ.	Max.	
Static Characteristics						
BV_{DSS}	Drain-Source Breakdown Voltage	$V_{GS}=0V, I_{DS}=250\mu A$	60			V
I_{DSS}	Zero Gate Voltage Drain Current	$V_{DS}=60V, V_{GS}=0V$ $T_J=85^{\circ}\text{C}$			1	μA
					30	
$V_{GS(th)}$	Gate Threshold Voltage	$V_{DS}=V_{GS}, I_{DS}=250\mu A$	2	3	4	V
I_{GSS}	Gate Leakage Current	$V_{GS}=\pm 25V, V_{DS}=0V$			± 100	nA
$R_{DS(ON)}^{(3)}$	Drain-Source On-state Resistance	$V_{GS}=10V, I_{DS}=40A$		2.8	3.5	$m\Omega$
Diode Characteristics						
$V_{SD}^{(3)}$	Diode Forward Voltage	$I_{SD}=40A, V_{GS}=0V$		0.8	1.3	V
t_{rr}	Reverse Recovery Time	$I_{SD}=40A, di_{SD}/dt=100A/\mu s$		75		ns
q_{rr}	Reverse Recovery Charge			150		nC
Dynamic Characteristics ⁽⁴⁾						
R_G	Gate Resistance	$V_{GS}=0V, V_{DS}=0V, F=1\text{MHz}$		1.4		Ω
C_{iss}	Input Capacitance	$V_{GS}=0V,$ $V_{DS}=30V,$ Frequency=1.0MHz		5800		μF
C_{oss}	Output Capacitance			1500		
C_{riss}	Reverse Transfer Capacitance			490		
$t_{d(ON)}$	Turn-on Delay Time	$V_{DD}=35V, R_L=35\Omega,$ $I_{DS}=1A, V_{GEN}=10V,$ $R_G=6\Omega$		22	41	ns
t_r	Turn-on Rise Time			38	70	
$t_{d(OFF)}$	Turn-off Delay Time			75	140	
t_f	Turn-off Fall Time			120	210	
Gate Charge Characteristics ⁽⁴⁾						
Q_g	Total Gate Charge	$V_{DS}=30V, V_{GS}=10V,$ $I_{DS}=40A$		155	220	nC
Q_{gs}	Gate-Source Charge			45		
Q_{gd}	Gate-Drain Charge			48		

- Notes: ① Pulse width limited by safe operating area.
 ② Current limited by package (Limitation Current is 75A)
 ③ Pulse test ; Pulse width $\leq 300\mu s$, duty cycle $\leq 2\%$.
 ④ Guaranteed by design, not subject to production testing.

Typical Characteristics

Power Dissipation

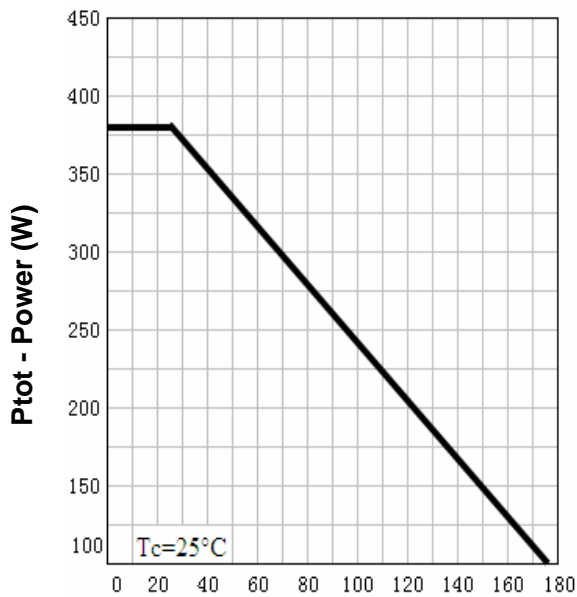

T_j - Junction Temperature (°C)

Drain Current

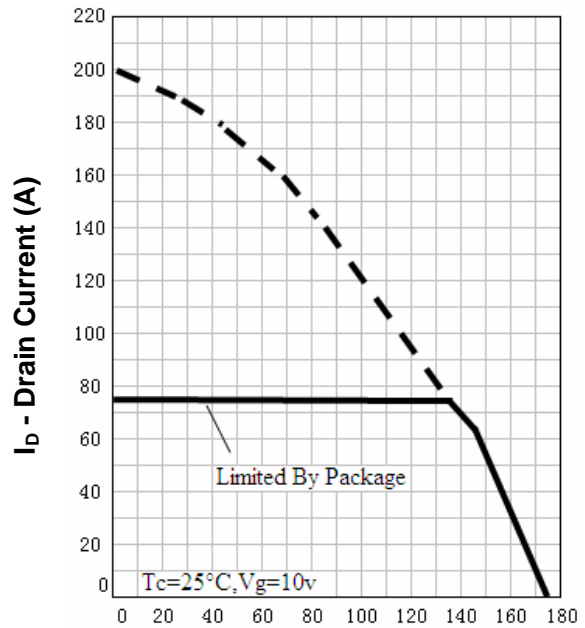

T_j - Junction Temperature (°C)

Safe Operation Area

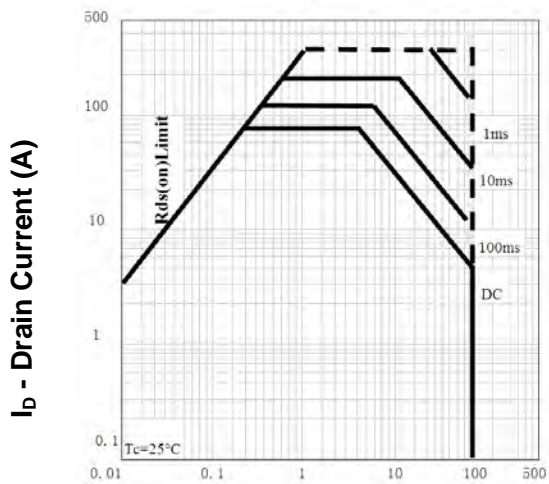

V_{DS} - Drain-Source Voltage (V)

Thermal Transient Impedance

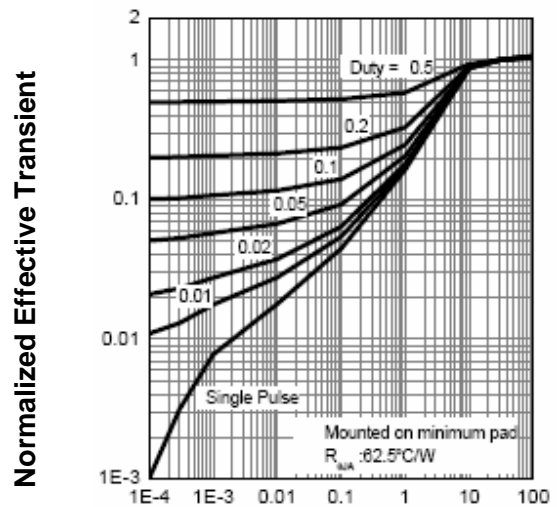

Square Wave Pulse Duration (sec)

Typical Characteristics

Output Characteristics

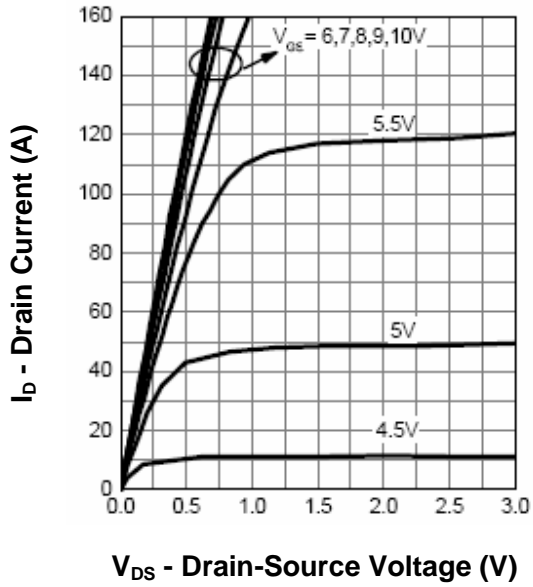

Drain-Source On Resistance

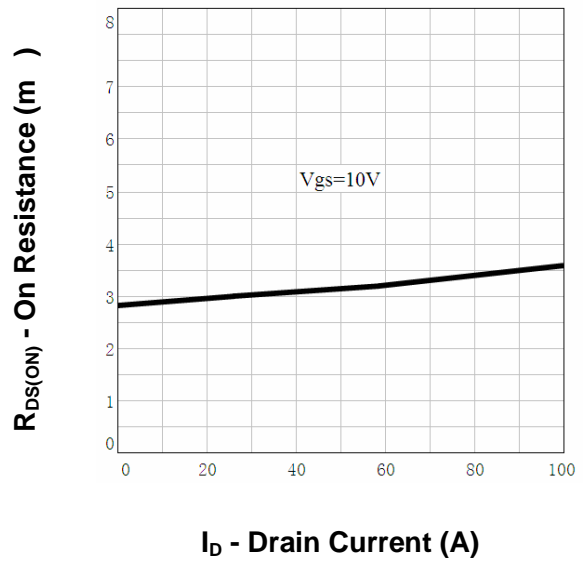

Drain-Source On Resistance

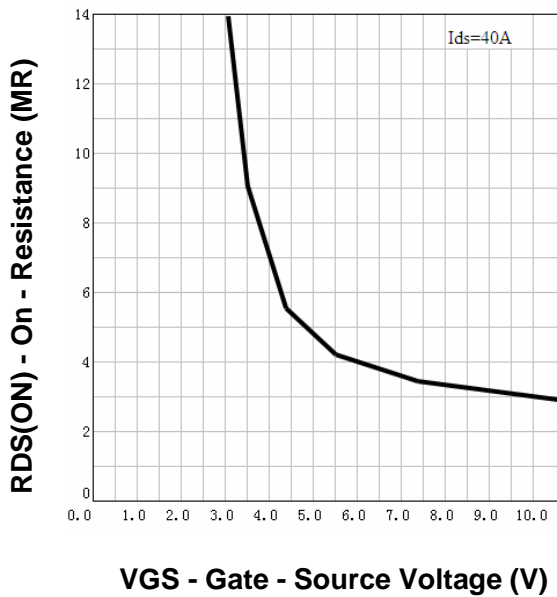

Gate Threshold Voltage

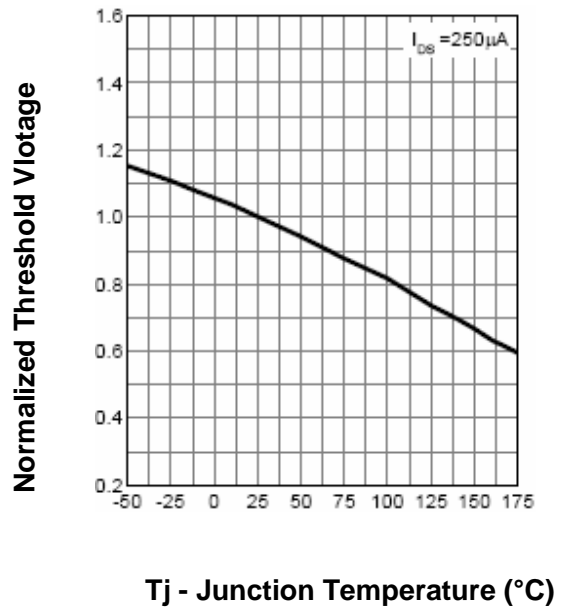

Typical Characteristics

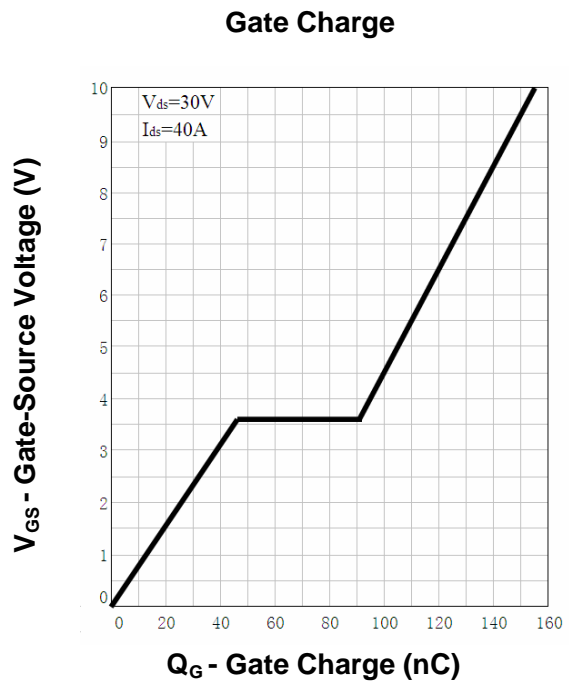
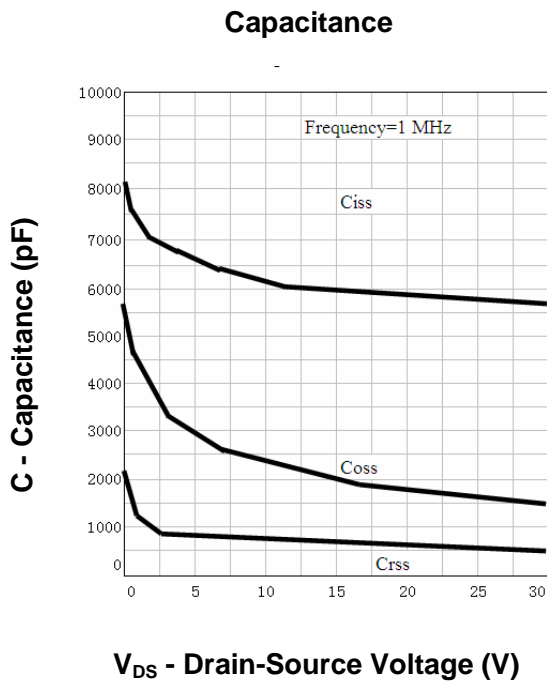
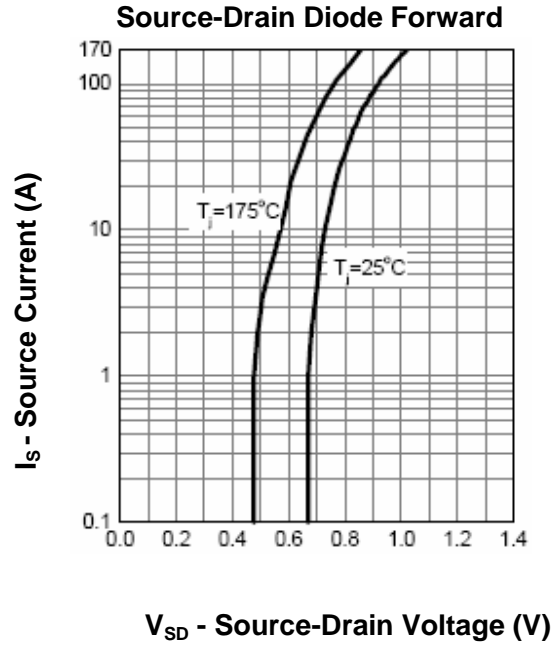
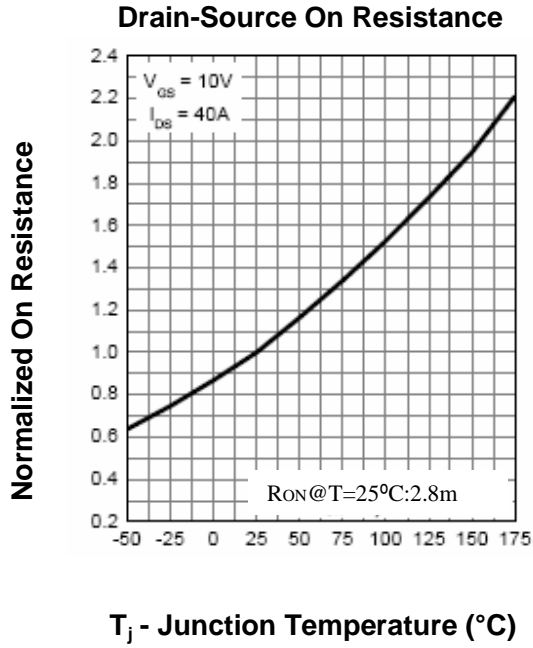

Avalanche Test Circuit and Waveforms

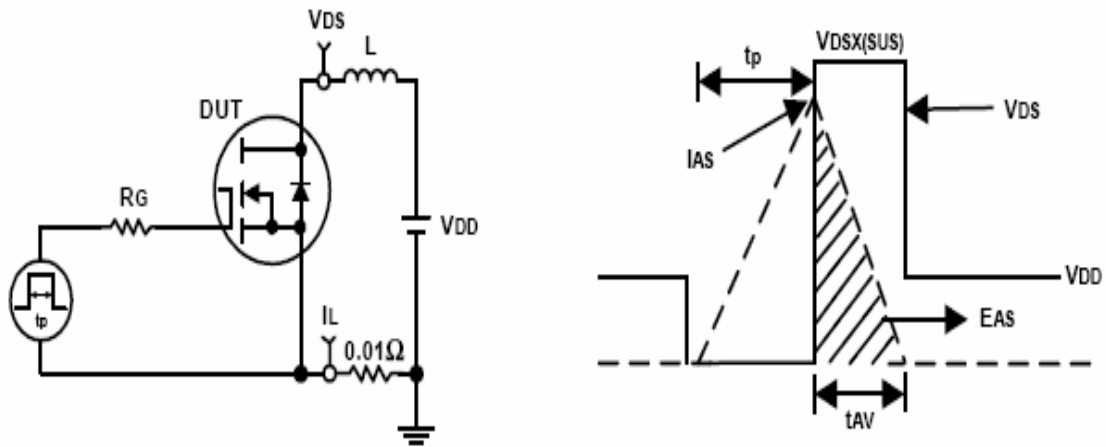

Switching Time Test Circuit and Waveforms

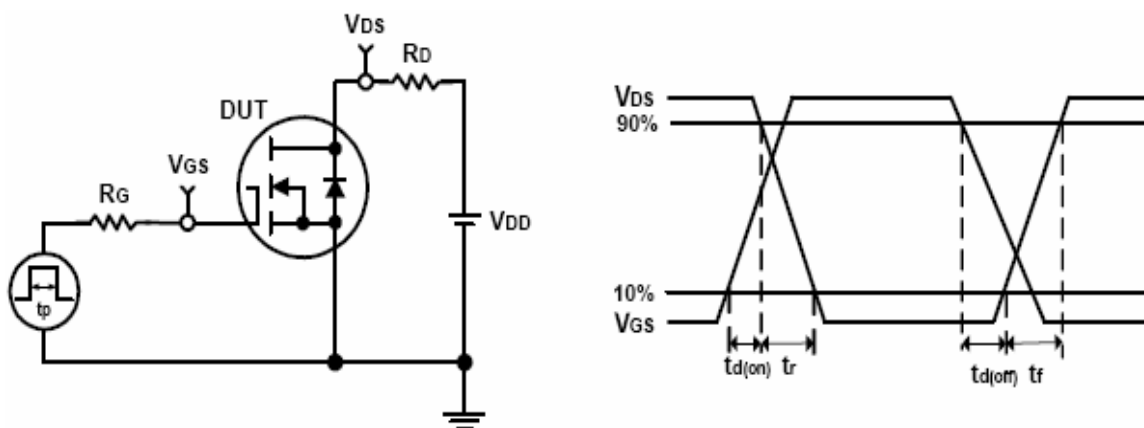

Ordering and Marking Information**RU6199****Package (Available)**

Q:TO-247 ; R: TO-220 ; S: TO-263 ; P: TO-220F

Operating Temperature Range

C : -55 to 175 °C

Assembly Material

G : Green & Lead Free Device

Packaging

T : TUBE

TR : Tape & Reel

Package Information

TO-220FB-3L



SYMBOL	MM			INCH			SYMBOL	MM			INCH		
	MIN	NOM	MAX	MIN	NOM	MAX		MIN	NOM	MAX	MIN	NOM	MAX
A	4.40	4.57	4.70	0.173	0.180	0.185	$\phi p1$	1.40	1.50	1.60	0.055	0.059	0.063
A1	1.27	1.30	1.33	0.050	0.051	0.052	e	2.54BSC			0.1BSC		
A2	2.35	2.40	2.50	0.093	0.094	0.098	e1	5.08BSC			0.2BSC		
b	0.77	-	0.90	0.030	-	0.035	H1	6.40	6.50	6.60	0.252	0.256	0.260
b2	1.23	-	1.36	0.048	-	0.054	L	12.75	-	13.17	0.502	-	0.519
C	0.48	0.50	0.52	0.019	0.020	0.021	L1	-	-	3.95	-	-	0.156
D	15.40	15.60	15.80	0.606	0.614	0.622	L2	2.50REF.			0.098REF.		
D1	9.00	9.10	9.20	0.354	0.358	0.362	ϕp	3.57	3.60	3.63	0.141	0.142	0.143
DEP	0.05	0.10	0.20	0.002	0.004	0.008	Q	2.73	2.80	2.87	0.107	0.110	0.113
E	9.70	9.90	10.10	0.382	0.389	0.398	$\theta 1$	5°	7°	9°	5°	7°	9°
E1	-	8.70	-	-	0.343	-	$\theta 2$	1°	3°	5°	1°	3°	5°
E2	9.80	10.00	10.20	0.386	0.394	0.401							

ALL DIMENSIONS REFER TO JEDEC STANDARD
DO NOT INCLUDE MOLD FLASH OR PROTRUSIONS

TO-263-2L

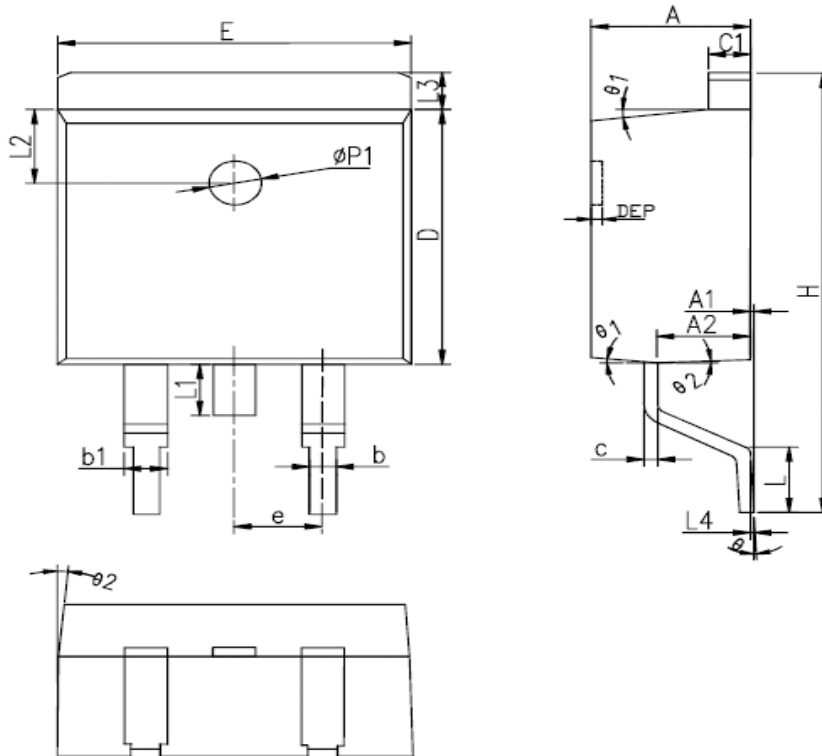

SYMBOL	MM			INCH			SYMBOL	MM			INCH		
	MIN	NOM	MAX	MIN	NOM	MAX		MIN	NOM	MAX	MIN	NOM	MAX
A	4.40	4.57	4.70	0.173	0.180	0.185	L	2.00	2.30	2.60	0.079	0.090	0.102
A1	0	0.10	0.25	0	0.004	0.010	L3	1.17	1.27	1.40	0.046	0.050	0.055
A2	2.59	2.69	2.79	0.102	0.106	0.110	L1	-	-	1.70	-	-	0.067
b	0.77	-	0.90	0.030	-	0.035	L4	0.25BSC			0.01BSC		
b1	1.23	-	1.36	0.048	-	0.052	L2	2.50REF.			0.098REF.		
c	0.34	-	0.47	0.013	-	0.019	θ	0°	-	8°	0°	-	8°
C1	1.22	-	1.32	0.048	-	0.052	θ 1	5°	7°	9°	5°	7°	9°
D	8.60	8.70	8.80	0.338	0.343	0.346	θ 2	1°	3°	5°	1°	3°	5°
E	10.00	10.16	10.26	0.394	0.4	0.404	DEP	0.05	0.10	0.20	0.002	0.004	0.008
e	2.54BSC			0.1BSC			Øp1	1.40	1.50	1.60	0.055	0.059	0.063
H	14.70	15.10	15.50	0.579	0.594	0.610							

ALL DIMENSIONS REFER TO JEDEC STANDARD
DO NOT INCLUDE MOLD FLASH OR PROTRUSIONS

TO-220F-3L

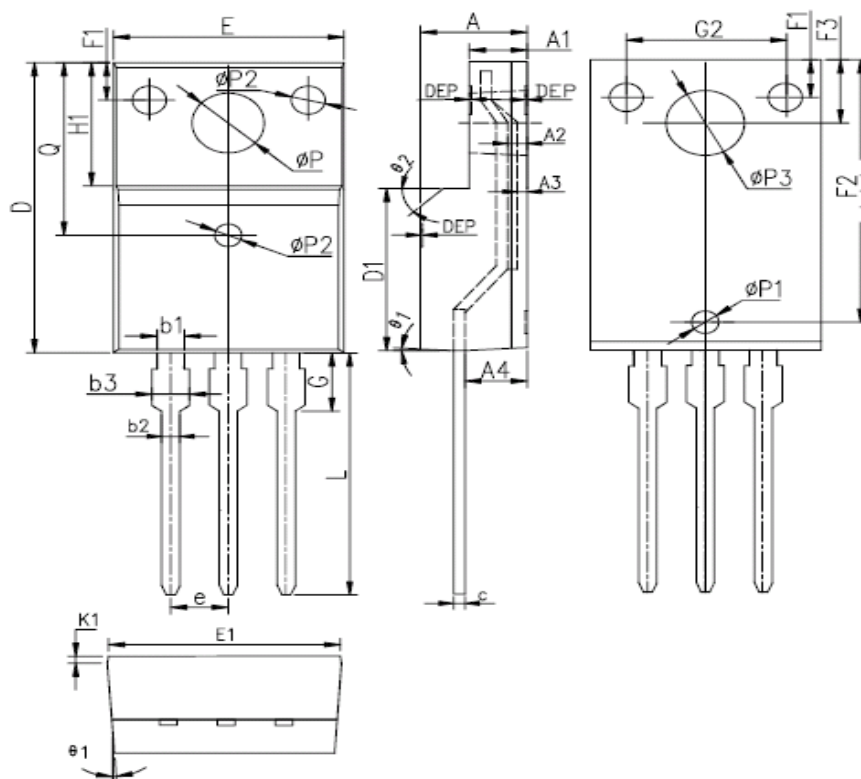

SYMBOL	MM			INCH			SYMBOL	MM			INCH		
	MIN	NOM	MAX	MIN	NOM	MAX		MIN	NOM	MAX	MIN	NOM	MAX
E	9.96	10.16	10.36	0.392	0.400	0.408	$\phi p3$	-	3.450	-	-	0.136	-
A	4.50	4.70	4.90	0.177	0.185	0.193	$\theta 1$	5°	7°	9°	5°	7°	9°
A1	2.34	2.54	2.74	0.092	0.100	0.108	$\theta 2$	-	45°	-	-	45°	-
A2	0.95	1.05	1.15	0.037	0.041	0.045	DEP	0.05	0.10	0.15	0.002	0.004	0.006
A3	0.42	0.52	0.62	0.017	0.020	0.024	F1	1.90	2.00	2.10	0.075	0.079	0.083
A4	2.65	2.75	2.85	0.104	0.108	0.112	F2	13.61	13.81	14.01	0.536	0.544	0.552
c	-	0.50	-	-	0.020	-	F3	3.20	3.30	3.40	0.126	0.130	0.134
D	15.67	15.87	16.07	0.617	0.625	0.633	G	3.25	3.45	3.65	0.128	0.136	0.144
Q	8.80	9.00	9.20	0.346	0.354	0.362	G1	5.90	6.00	6.10	0.232	0.236	0.240
H1	6.48	6.68	6.88	0.255	0.263	0.271	G2	6.90	7.00	7.10	0.272	0.276	0.280
e	2.54BSC			0.1BSC			b1	1.17	1.20	1.24	0.046	0.047	0.048
ϕp	-	3.183	-	-	0.125	-	b2	0.77	0.8	0.85	0.030	0.031	0.033
L	12.78	12.98	13.18	0.503	0.511	0.519	b3	1.10	1.30	1.50	0.043	0.051	0.059
D1	8.99	9.19	9.39	0.354	0.362	0.370	E1	9.8	10.00	10.20	0.386	0.394	0.412
$\phi p1$	1.40	1.50	1.60	0.055	0.059	0.063	K1	0.75	0.8	0.85	0.030	0.031	0.033
$\phi p2$	1.15	1.20	1.25	0.045	0.047	0.049							

ALL DIMENSIONS REFER TO JEDEC STANDARD
DO NOT INCLUDE MOLD FLASH OR PROTRUSIONS

TO-247

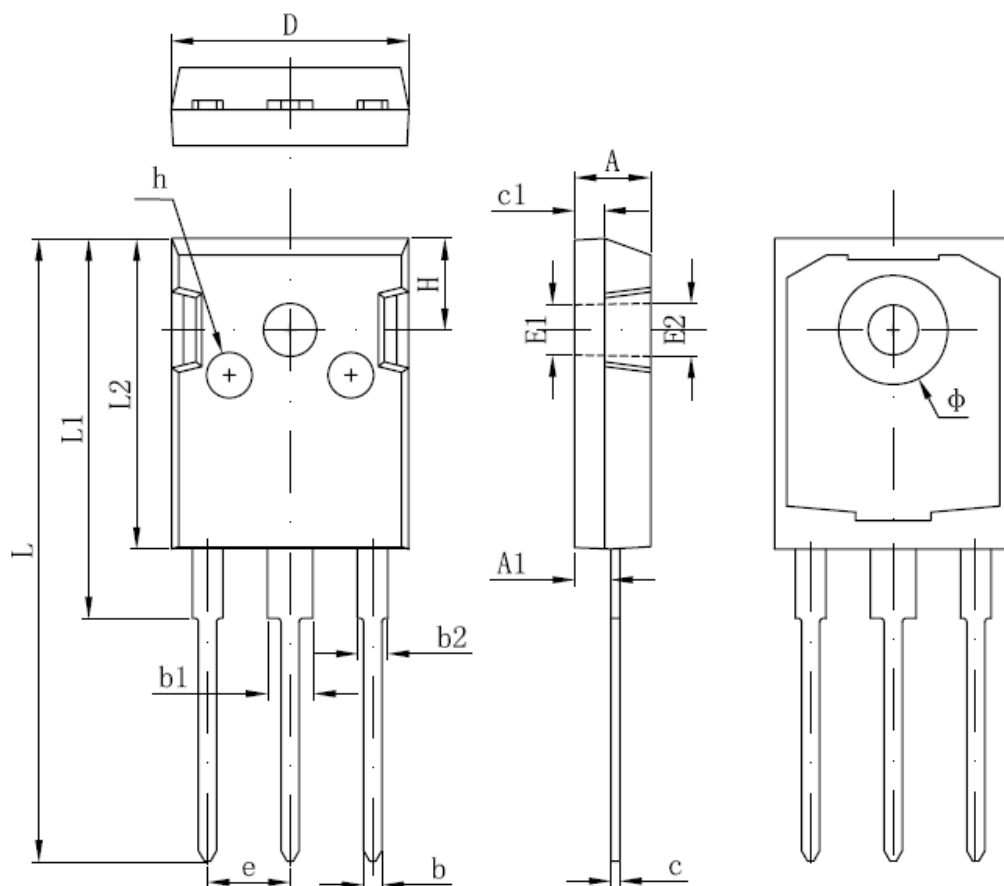

SYMBOL	MM		INCH		SYMBOL	MM		INCH	
	MIN	MAX	MIN	MAX		MIN	MAX	MIN	MAX
A	4.850	5.150	0,191	0.200	E2	3.600 REF		0.142 REF	
A1	2.200	2.600	0.087	0.102	L	40.900	41.300	1.610	1.626
B	1.000	1.400	0.039	0.055	L1	24.800	25.100	0.976	0.988
b1	2.800	3.200	0.110	0.126	L2	20.300	20.600	0.799	0.811
b2	1.800	2.200	0.071	0.087	Φ	7.100	7.300	0.280	0.287
c	0.500	0.700	0.020	0.028	e	5.450 TYP		0.215 TYP	
c1	1.900	2.100	0.075	0.083	H	5.980 REF.		0.235 REF.	
D	15.450	15.750	0.608	0.620	h	0.000	0.300	0.000	0.012
E1	3.500 REF.		0.138 REF.						

ALL DIMENSIONS REFER TO JEDEC STANDARD
DO NOT INCLUDE MOLD FLASH OR PROTRUSIONS