

LM3414/LM3414HV

1A 60W* Common Anode Capable Constant Current Buck LED Driver Requires No External Current Sensing Resistor

General Description

The LM3414 and LM3414HV are 1A 60W* common anode capable constant current buck LED drivers. They are exceptionally suitable to drive single string of 3W HBLED with up to 96% efficiency. They accept input voltages from 4.5VDC to 65VDC and deliver up to 1A average LED current with $\pm 3\%$ accuracy. The integrated low-side N-channel power MOSFET and current sensing element realize simple and low component count circuitry as no bootstrapping capacitor and external current sensing resistor are required. An external small-signal resistor to ground provides very fine LED current adjustment, analog dimming as well as thermal fold-back functions.

Constant switching frequency operation eases EMI. No external loop compensation network is needed. The proprietary Pulse-Level-Modulation (PLM) control method benefits in high conversion efficiency and true average LED current regulation. Fast response time realizes fine LED current pulse fulfilling the 240 Hz 256-step dimming resolution requirement for general lighting.

The LM3414 and LM3414HV are available in ePSOP-8 and 3mm x 3mm LLP-8 packages.

*Thermal de-rating applies according to actual operation conditions

Features

- Support LED power up to 60W*: 18x 3W HBLEDs
- Requires NO external current sensing resistor
- $\pm 3\%$ LED current accuracy
- Up to 96% efficiency
- High contrast ratio (Minimum dimming current pulse width $< 10 \mu\text{s}$)
- Integrated low-side N-channel MOSFET
- Adjustable Constant LED current from 350mA to 1000mA
- Support analog dimming and thermal fold-back
- Wide input voltage range:
4.5V to 42V (LM3414)
4.5V to 65V (LM3414HV)
- Constant Switching Frequency adjustable from 250 kHz to 1000 kHz
- Thermal shutdown protection
- Power enhanced ePSOP-8 or 3mm x 3mm LLP-8 package

Applications

- High Power LED Driver
- Architectural Lighting, Office Troffer
- Automotive Lighting
- MR-16 LED Lamp

Simplified Application Schematic

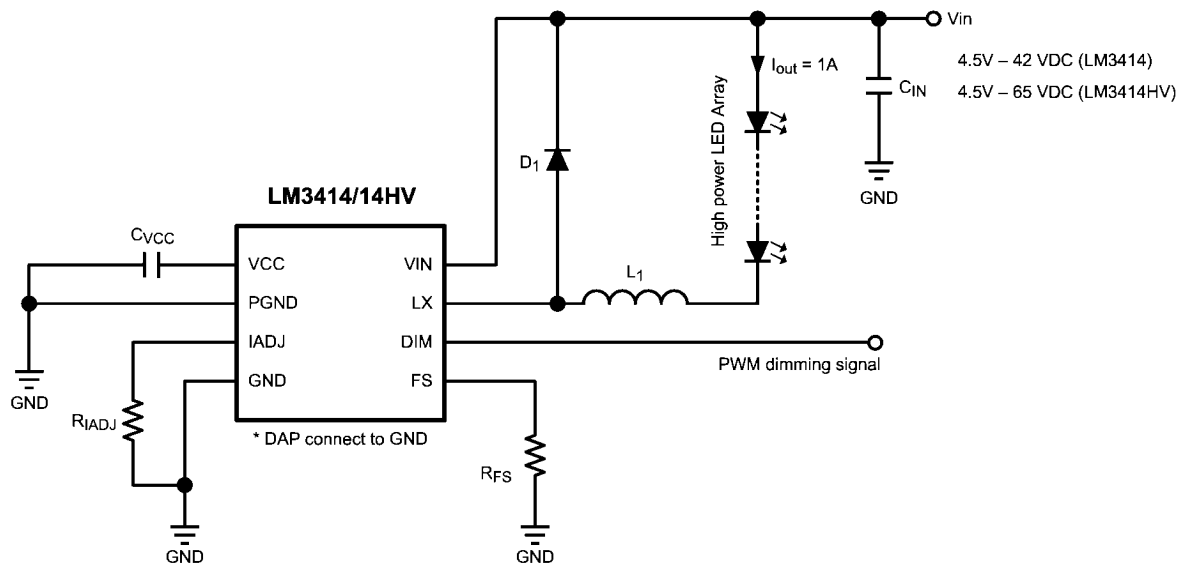

30124801

Connection Diagram

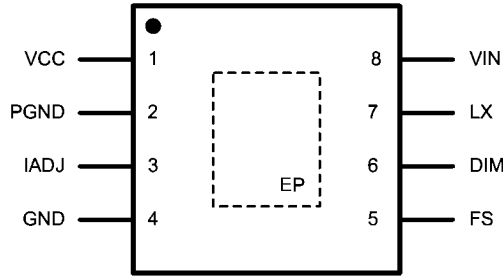

Top View
8 – Lead Plastic ePSOP-8
NS Package Number MRA08A

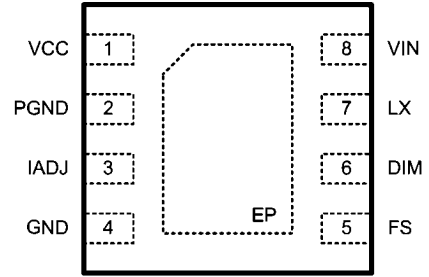

Top View
8 – Lead Plastic LLP-8
NS Package Number SDA08AG

30124803

Ordering Information

Order Number	Package Type	NSC Package Drawing	Supplied As
LM3414MR	ePSOP-8	MRA08A	95 Units in Anti-Static Rails
LM3414MRX			2,500 Units on Tape and Reel
LM3414HVMR			95 Units in Anti-Static Rails
LM3414HVMRX			2500 Units on Tape and Reel
LM3414SD	LLP-8	SDA08AG	1,000 Units on Tape and Reel
LM3414SDX			4,500 Units on Tape and Reel
LM3414HVSD			1,000 Units on Tape and Reel
LM3414HVSDX			4,500 Units on Tape and Reel

Pin Descriptions

Pin(s)	Name	Description	Application Information
1	VCC	Internal Regulator Output Pin	This pin should be bypassed to ground by a ceramic capacitor with a minimum value of 1 μ F.
2	PGND	Power Ground Pin	Ground for power circuitry. Reference point for all stated voltages. Must be externally connected to EP and GND.
3	IADJ	Average Output Current Adjustment Pin	Connect resistor R_{IADJ} from this pin to ground to adjust the average output current.
4	GND	Analog Ground Pin	Analog ground connection for internal circuitry, must be connected to PGND external to the package.
5	FS	Switching Frequency Setting Pin	Connect resistor R_{FS} from this pin to ground to set the switching frequency.
6	DIM	PWM Dimming Control Pin	Apply logic level PWM signal to this pin controls the intend brightness of the LED string.
7	LX	Drain of N-MOSFET Switch	Connect this pin to the output inductor and anode of the schottky diode.
8	VIN	Input Voltage Pin	The input voltage should be in the range of 4.5V to 42V (LM3414) or 4.5V to 65V (LM3414HV).
EP	EP	Thermal Pad (Power Ground)	Used to dissipate heat from the package during operation. Must be electrically connected to PGND external to the package.

Absolute Maximum Ratings

(LM3414) (Note 1)

If Military/Aerospace specified devices are required, please contact the National Semiconductor Sales Office/Distributors for availability and specifications.

VIN to GND	-0.3V to 42V
VIN to GND (Transient)	45V (500 ms)
LX to PGND	-0.3V to 42V
LX to PGND (Transient)	-3V(2 ns) to 45V (500 ms)
FS, IADJ to GND	-0.3V to 5V
DIM to GND	-0.3V to 6V
ESD Rating	
Human Body Model (Note 2)	2kV

Storage Temp. Range -65°C to 125°C

Soldering Information

Lead Temp. (Soldering 10s) 260°C

Infrared/Convection Reflow (20sec) 235°C

Operating Ratings (LM3414)

V_{IN} 4.5V to 42V

Junction Temperature Range -40°C to +125°C

Thermal Resistance θ_{JA}
(ePSOP-8 Package) 45°C/W

Thermal Resistance θ_{JA}
(LLP-8 Package) 54°C/W

Absolute Maximum Ratings

(LM3414HV) (Note 1)

If Military/Aerospace specified devices are required, please contact the National Semiconductor Sales Office/Distributors for availability and specifications.

V _{IN} to GND	-0.3V to 65V
V _{IN} to GND (Transient)	67V (500 ms)
LX to PGND	-0.3V to 65V
LX to PGND (Transient)	-3V(2 ns) to 67V (500 ms)
FS, IADJ to GND	-0.3V to 5V
DIM to GND	-0.3V to 6V
ESD Rating	
Human Body Mode (Note 2)	2kV

Storage Temp. Range -65°C to 125°C

Soldering Information

Lead Temp. (Soldering 10s)	260°C
Infrared/Convection Reflow (20sec)	235°C

Operating Ratings (LM3414HV)

V _{IN}	4.5V to 65V
Junction Temperature Range	-40°C to +125°C
Thermal Resistance θ_{JA} (ePSOP-8 Package)	45°C/W
Thermal Resistance θ_{JA} (LLP-8 Package)	54°C/W

Electrical Characteristics $V_{IN} = 24V$ unless otherwise indicated. Typical and limits appearing in plain type apply for $T_A = T_J = +25^\circ C$ (Note 4). Limits appearing in boldface type apply over full Operating Temperature Range. Datasheet min/max specification limits are obtained under device test mode and guaranteed by design, test, or statistical analysis.

LM3414

Symbol	Parameter	Conditions	Min	Typ	Max	Units
SYSTEM PARAMETERS						
$I_{IN-DIM-HIGH}$	Operating Current	$4.5V \leq V_{in} \leq 42V$ $R_{IADJ} = 3.125 k\Omega$ $V_{DIM} = High$	2.2	3.2	3.5	mA
$I_{IN-DIM-LOW}$	Standby Current	$4.5V \leq V_{in} \leq 42V$ $R_{IADJ} = 3.125 k\Omega$ $V_{DIM} = Low$	0.8	1.15	1.4	mA
I_{LX-OFF}	LX Pin Current	Main Switch Turned OFF $V_{LX} = V_{IN} = 42V$		6		μA

LM3414HV

Symbol	Parameter	Conditions	Min	Typ	Max	Units
SYSTEM PARAMETERS						
$I_{IN-DIM-HIGH}$	Operating Current	$4.5V \leq V_{in} \leq 65V$ $R_{IADJ} = 3.125 k\Omega$ $V_{DIM} = High$	2.2	3.3	3.6	mA
$I_{IN-DIM-LOW}$	Standby Current	$4.5V \leq V_{in} \leq 65V$ $R_{IADJ} = 3.125 k\Omega$ $V_{DIM} = Low$	0.8	1.2	1.45	mA
I_{LX-OFF}	LX Pin Current	Main Switch Turned OFF $V_{LX} = V_{IN} = 65V$		6.5		μA

LM3414/LM3414HV

Symbol	Parameter	Conditions	Min	Typ	Max	Units
SYSTEM PARAMETERS						
I_{LED}	Average LED Current	$R_{IADJ} = 3.125 k\Omega$ $T_A = 25^\circ C$	0.97	1	1.03	A
		$R_{IADJ} = 3.125 k\Omega$ $T_A = -40^\circ C$ to $125^\circ C$	0.95	1	1.05	A
$V_{CC-UVLO}$	Vcc UVLO Threshold	V_{CC} Decreasing	3.60	3.75	3.90	V
$V_{CC-UVLO-HYS}$	Vcc UVLO Hysteresis			300		mV
V_{IADJ}	IADJ Pin voltage		1.230	1.255	1.280	V
V_{DIM}	DIM Pin Threshold	V_{DIM} Increasing		1.0	1.2	V
$V_{DIM-HYS}$	DIM Pin Hysteresis			100		mV
f_{SW}	Switching Frequency Range		250	500	1000	kHz
f_{SW-TOL}	Switching Frequency Tolerance	$R_{FS} = 40 k\Omega$	420	500	580	kHz
t_{ON-MIN}	Minimum On-time				400	ns
INTERNAL VOLTAGE REGULATOR						
V_{CC}	V_{CC} Regulator Output Voltage (Note 5)	$C_{VCC} = 1\mu F$, No Load to $I_{VCC} = 2mA$	4.7	5.4	6.0	V
		$V_{in} = 4.5V$, 2 mA Load	3.8	4.2		V
MAIN SWITCH						
R_{LX}	Resistance Across LX and GND	Main Switch Turned ON			1.8	Ω
THERMAL PROTECTION						
T_{SD}	Thermal Shutdown Temperature	T_J Rising		170		$^\circ C$

Symbol	Parameter	Conditions	Min	Typ	Max	Units
T_{SD-HYS}	Thermal Shutdown Temperature Hysteresis	T_J Falling		10		$^{\circ}C$
THERMAL RESISTANCE						
θ_{JA}	Junction to Ambient,	ePSOP-8 package		45		$^{\circ}C/W$
	0 LFPM Air Flow (Note 3)	LLP-8 package		54		$^{\circ}C/W$

Note 1: Absolute Maximum Ratings are limits beyond which damage to the device may occur. Operating Ratings are conditions under which operation of the device is intended to be functional. For guaranteed specifications and test conditions, see the Electrical Characteristics.

Note 2: The human body model is a 100pF capacitor discharged through a 1.5 k Ω resistor into each pin.

Note 3: Tested on a 4 layer JEDEC board. Four vias provided under the exposed pad. See JESD51-5 and JESD51-7. The value of the θ_{JA} for the LLP package is specifically dependent on the PCB trace area, trace material, and the number of layers and thermal vias. For improved thermal resistance and power dissipation for the LLP package, refer to Application Note AN-1187.

Note 4: Typical specification represent the most likely parametric norm at 25 $^{\circ}C$ operation.

Note 5: VCC provides self bias for the internal gate drive and control circuits. Device thermal limitations limit external loading to the pin.

Typical Performance Characteristics All curves taken at $V_{IN} = 48V$ with configuration in typical application for driving twelve power LEDs with $I_{LED} = 1A$ shown in this datasheet. $T_A = 25^\circ C$, unless otherwise specified.

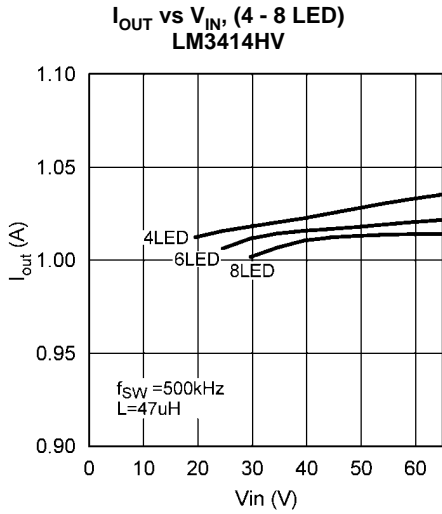

30124843

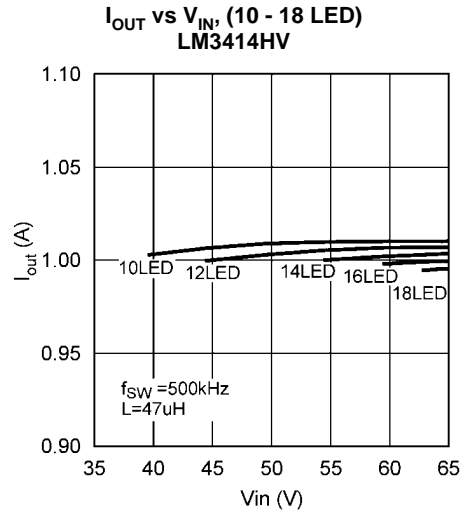

30124844

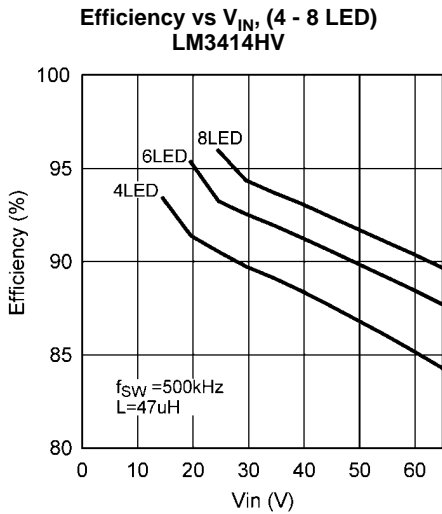

30124859

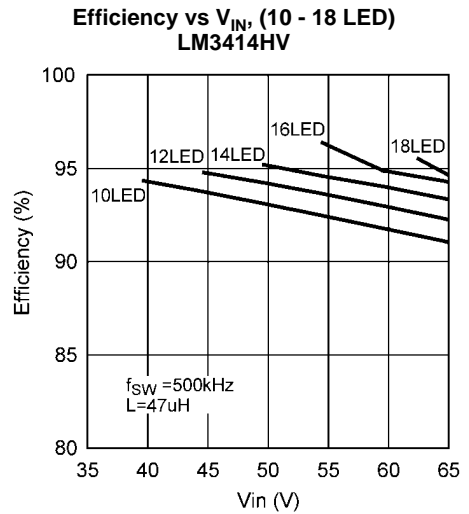

30124860

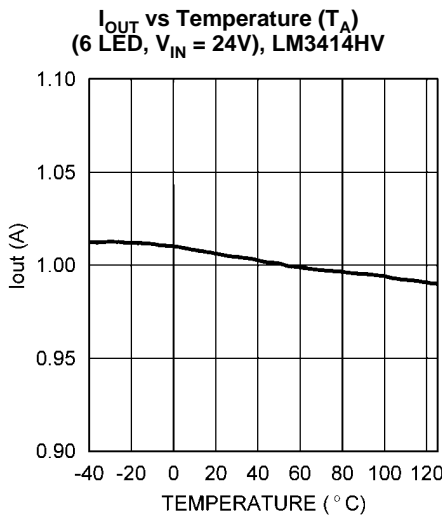

30124841

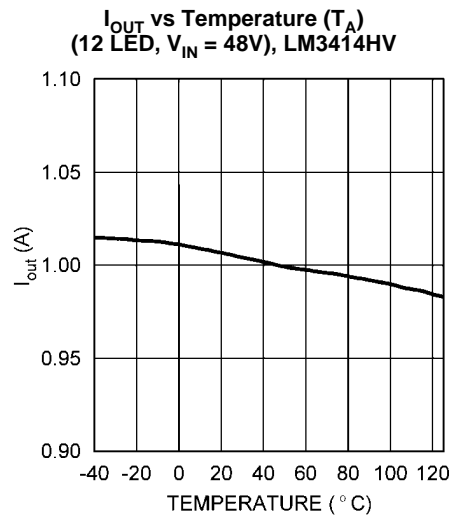

30124842

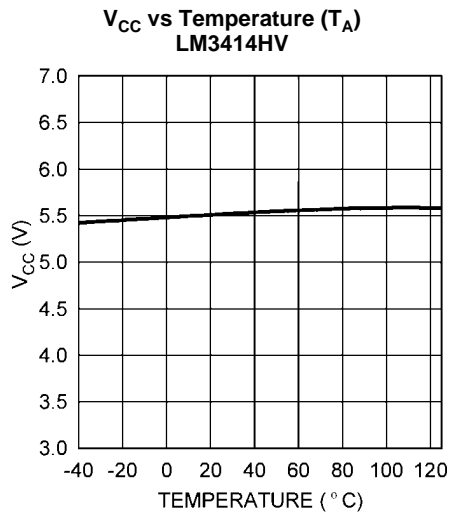

30124839

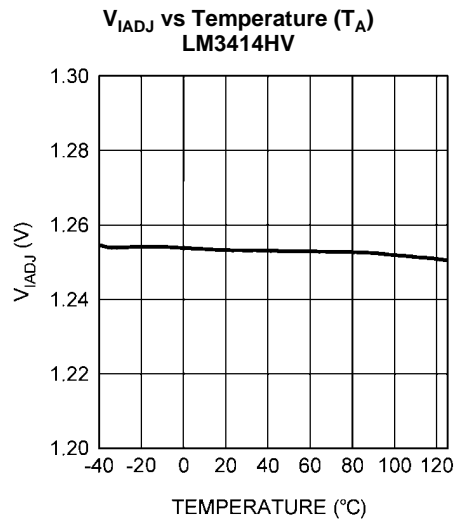

30124840

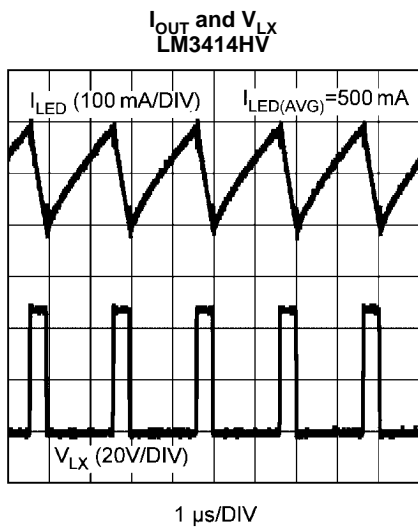

30124816

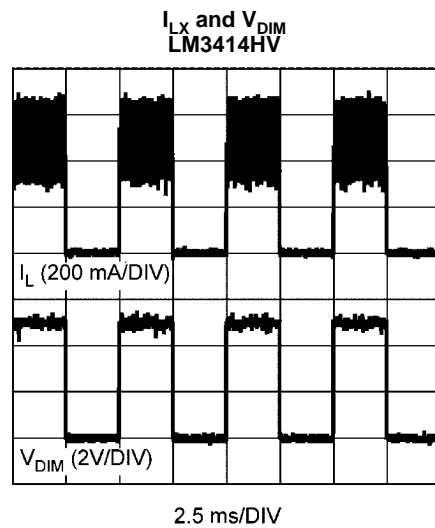

30124817

**LED Current with PWM Dimming (V_{DIM} Rising)
LM3414HV**

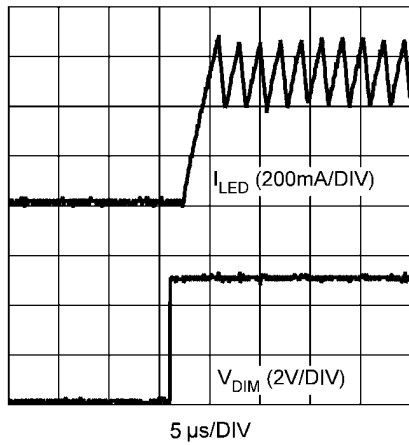

30124856

**LED Current with PWM Dimming (V_{DIM} Falling)
LM3414HV**

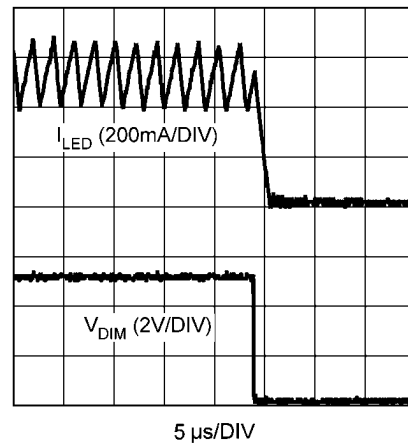

30124857

LED Current with PWM Dimming
(9 μ s dimming pulse), LM3414HV

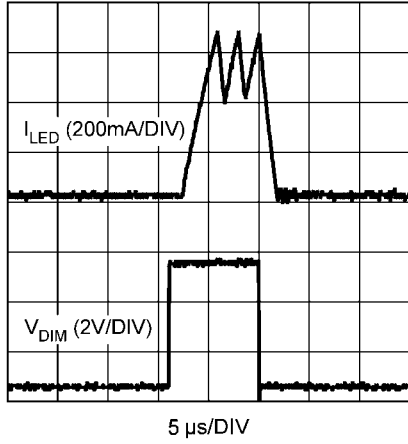

30124858

Block Diagram

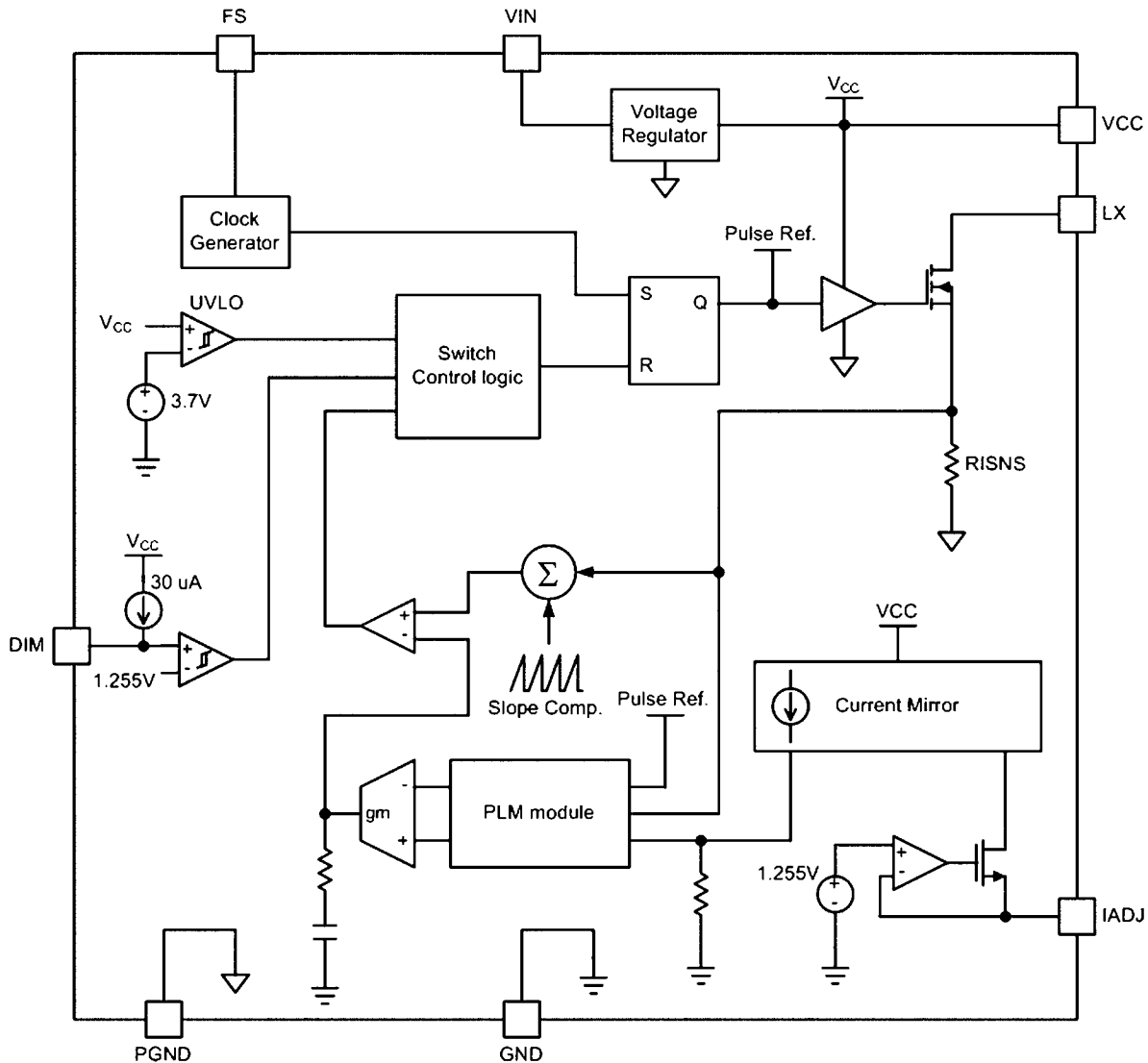

30124820

Operation Description

OVERVIEW

The LM3414/14HV is a high power floating buck LED driver with wide input voltage ranges. It requires no external current sensing elements and loop compensation networks. The integrated power N-MOSFET enables high output power with up to 1000 mA output current. The combination of Pulse Width Modulation (PWM) control architecture and the proprietary Pulse Level Modulation (PLM) guarantees accurate current regulation, good EMI performance and provides high flexibility on inductor selection. High speed dimming control input allows precision and high resolution brightness control for applications require fine brightness adjustment.

Application Information

SETTING THE SWITCHING FREQUENCY

Both the LM3414 and LM3414HV are PWM LED drivers that contain a clock generator to generate constant switching frequency for the device. The switching frequency is determined by the resistance of an external resistor R_{FS} in the range of 250 kHz to 1 MHz. Lower resistance of R_{FS} results in higher switching frequency. The switching frequency of the LM3414/14HV is governed by the following equation:

$$f_{sw} = \frac{20 \times 10^6}{R_{FS}} \text{ kHz}$$

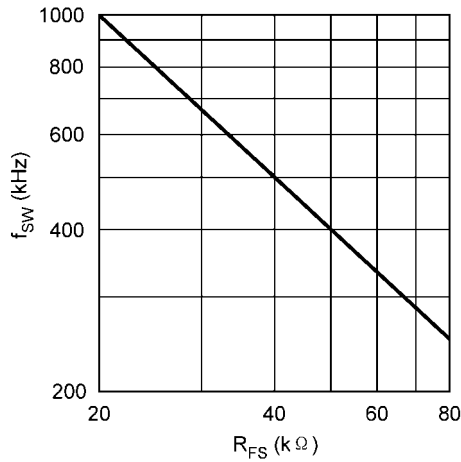

30124845

FIGURE 1. Switching Frequency vs R_{FS}

f_{SW} (kHz)	R_{FS} (k Ω)
250	80
500	40
1000	20

TABLE 1. Examples for f_{SW} Settings

To ensure accurate current regulation, the LM3414/14HV should be operated in continuous conduction mode (CCM) and the on time should not be shorter than 400 ns under all operation condition.

SETTING LED CURRENT

The LM3414/14HV requires no external current sensing resistor for LED current regulation. The average output current of the LM3414/14HV is adjustable by varying the resistance of the resistor, R_{IADJ} that connects across the IADJ and GND pins. The IADJ pin is internally biased to 1.255V. The LED current is then governed by the following equation:

$$I_{LED} = \frac{3125 \times 10^3}{R_{IADJ}} \text{ mA}$$

where $350 \text{ mA} < I_{LED} < 1 \text{ A}$

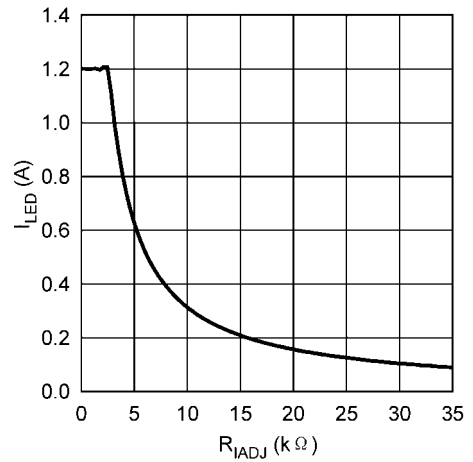

30124822

FIGURE 2. LED Current vs R_{IADJ}

I_{OUT} (mA)	R_{IADJ} (k Ω)
350	8.93
500	6.25
700	4.46
1000	3.13

TABLE 2. Examples for I_{OUT} Settings

The LED current can be set to any level in the range from 350 mA to 1A. In order to provide accurate LED current, R_{IADJ} should be a resistor with no more than 0.5% tolerance. If the IADJ pin is accidentally shorted to GND ($R_{IADJ} = 0$), the output current will be limited to avoid damaging the circuit. When the over current protection is activated, current regulation cannot be maintained until the over-current condition is cleared.

MINIMUM SWITCH ON-TIME

As the LM3414 features a 400 ns minimum ON time, it is essential to make sure the ON time of the internal switch is not shorter than 400 ns when setting the LED driving current. If the switching ON time is shorter than 400 ns, the accuracy of the LED current may not maintain and exceed the rated current of the LEDs. The ratio of the LED forward voltage to input voltage is restricted by the following restriction:

$$\frac{V_{LED}}{V_{IN}} \geq 400 \text{ nS} \times f_{SW}$$

PEAK SWITCH CURRENT LIMIT

The LM3414/14HV features an integrated switch current limiting mechanism that protects the LEDs from being overdriven. The switch current limiter will be triggered when the switch current is three times exceeding the current level set by R_{IADJ} . Once the current limiter is triggered, the internal power switch turns OFF for 3.6 μs to allow the inductor to discharge and cycles repetitively until the over current condition is removed. The current limiting feature is exceptionally important to avoid permanent damage of the LM3414/14HV application circuit due to short circuit of LED string.

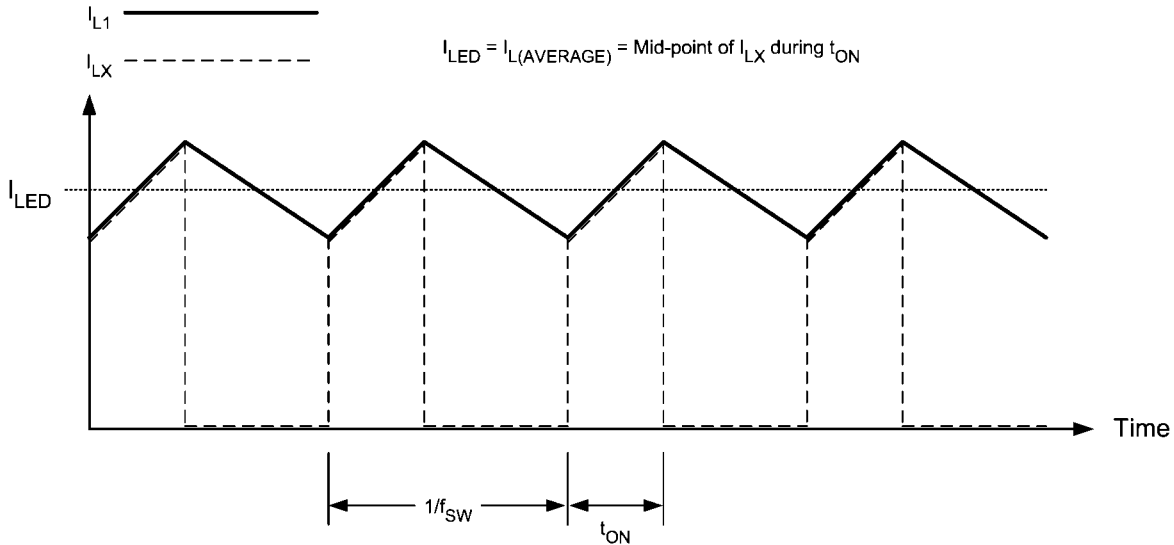

30124823

FIGURE 3. Waveforms of a Floating Buck LED Driver with PLM

INDUCTOR SELECTION

To ensure proper output current regulation, the LM3414/14HV must operate in Continuous Conduction Mode (CCM). With the incorporation of PLM, the peak-to-peak inductor current ripple can be set as high as $\pm 60\%$ of the defined average output current. The minimum inductance of the inductor is decided by the defined average LED current and allowable inductor current ripple. The minimum inductance can be found by the equations shown in below:

Since:

$$\Delta I_L = \frac{V_{IN} - V_{LED}}{L} \times D \times T$$

Thus:

$$L_{MIN} = \frac{V_{IN} - V_{LED}}{1.2 \times I_{LED}} \times \frac{V_{LED}}{V_{IN}} \times \frac{1}{f_{SW}}$$

The LM3414/14HV can maintain LED current regulation without output filter capacitor. This is because the inductor of the floating buck structure provides continuous current to the LED throughout the entire switching cycle. When LEDs are driven without filter capacitor, the LED peak current must not set exceeding the rated current of the LED. The peak LED current is governed by the following equation:

$$\Delta I_L = \left[\frac{(V_{IN} - V_{LED})V_{LED}}{2L \times V_{IN} \times f_{SW}} \right] + I_{LED(AVG)}$$

INTERNAL N_MOS POWER SWITCH

The LM3414/14HV features an integrated N-channel power MOSFET that connects between the LX and GND pins for power switching. With the switch turned ON, the resistance across the LX and GND pins is 1.8Ω maximum.

INTERNAL VCC REGULATOR

The LM3414/14HV features a 5.4V internal voltage regulator that connects between the VIN and VCC pins for powering internal circuitry and provide biases to external components. The VCC pin must be bypassed to the GND pin with a $1\mu\text{F}$ ceramic capacitor, C_{VCC} that connected to the pins as close as possible. When the input voltage falls below 6V, the VCC voltage will drop below 5.4V and decrease proportionally as V_{in} decreases. The device will shutdown as the VCC voltage falls below 3.9V. When the internal regulator is used to provide bias to external circuitry, it is essential to ensure the current sinks from VCC pin does not exceed 2mA to maintain correct voltage regulation.

CONTROL SCHEME

The main control circuitry of the LM3414/14HV is generally a Pulse-Width-Modulated (PWM) controller with the incorporation of the Pulse-Level-Modulation (PLM) technology. PLM is a technology that facilitates true output average current control without the need to sense the output current directly. In the LM3414/LM3414HV, the PLM circuit senses the current of the internal switch through an integrated current sensing circuitry to realize average output current control. The use of PLM reduces the power losses on current sensor as it needs current information only when the switch is turned ON.

In general, the LED drivers with current sensing resistor at the output, the power dissipation on the current sensing resistor is $I_{LED}^2 \times R_{ISNS}$, where I_{LED} is the average output current and R_{ISNS} is the resistance of the current sensing resistor. In the LM3414/LM3414HV, because of the incorporation of PLM, power dissipates on the R_{ISNS} only in ON period of the internal power switch. The power loss on R_{ISNS} becomes $I_{LED}^2 \times R_{ISNS} \times D$, where D is the switching duty cycle. For example, when the switching duty cycle, D of a converter is 0.5, the power loss on R_{ISNS} with PLM is half of those with conventional output current sensing.

PULSE-LEVEL-MODULATION (PLM) OPERATION PRINCIPLES

The Pulse-Level-Modulation is a patented method to ensure accurate average output current regulation without the need of direct output current sensing. Figure 3 shows the current waveforms of a typical buck converter under steady state, where, I_{L1} is the inductor current and I_{LX} is the main switch current flowing into the LX pin. For a buck converter operating in steady state, the mid-point of the RAMP section of the main switch current is equal to the average level of the inductor current hence the average output current. In short, by regulating the mid-point of the RAMP section of the main switch current with respect to a precise reference level, PLM achieves output current regulation by sensing the main switch current solely.

PWM DIMMING CONTROL

The DIM pin of the LM3414/14HV is an input with internal pull-up that accepts logic signals for average LED current control. Applying a logic high (above 1.2V) signal to the DIM pin or leaving the DIM pin open will enable the device. Applying a logic low signal (below 0.9V) to the DIM pin will disable the switching activity of the device but maintain VCC regulator active. The LM3414/14HV allows the inductor current to slew up to the preset regulated level at full speed instead of charging the inductor with multiple restrained switching duty cycles. This enables the LM3414/14HV to achieve high speed dimming and very fine dimming control as shown in Figure 4 and Figure 5:

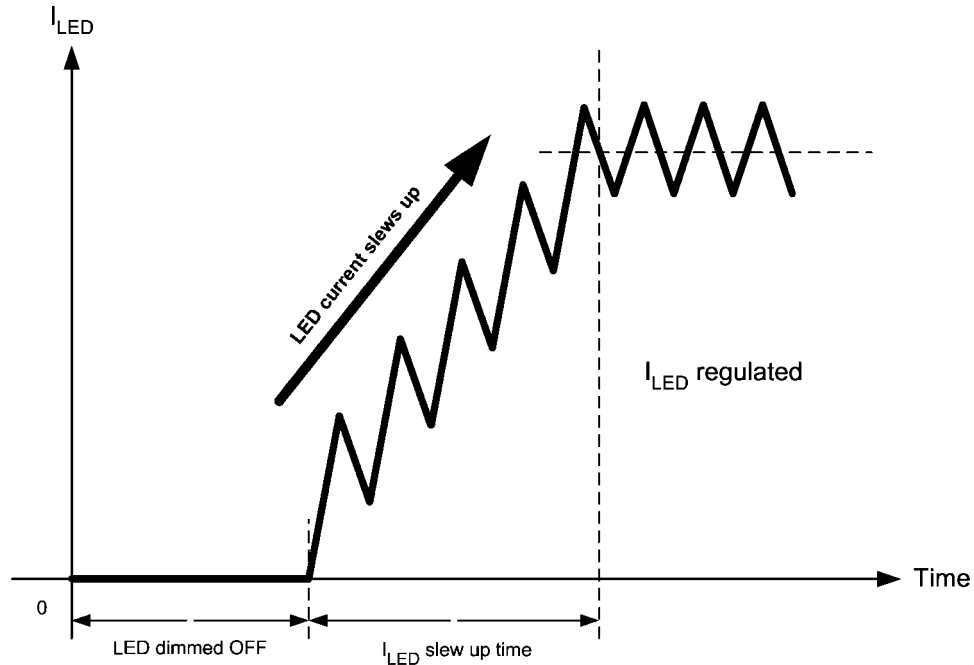

30124824

FIGURE 4. LED Current SLEWS UP WITH MULTIPLE SWITCHING CYCLE

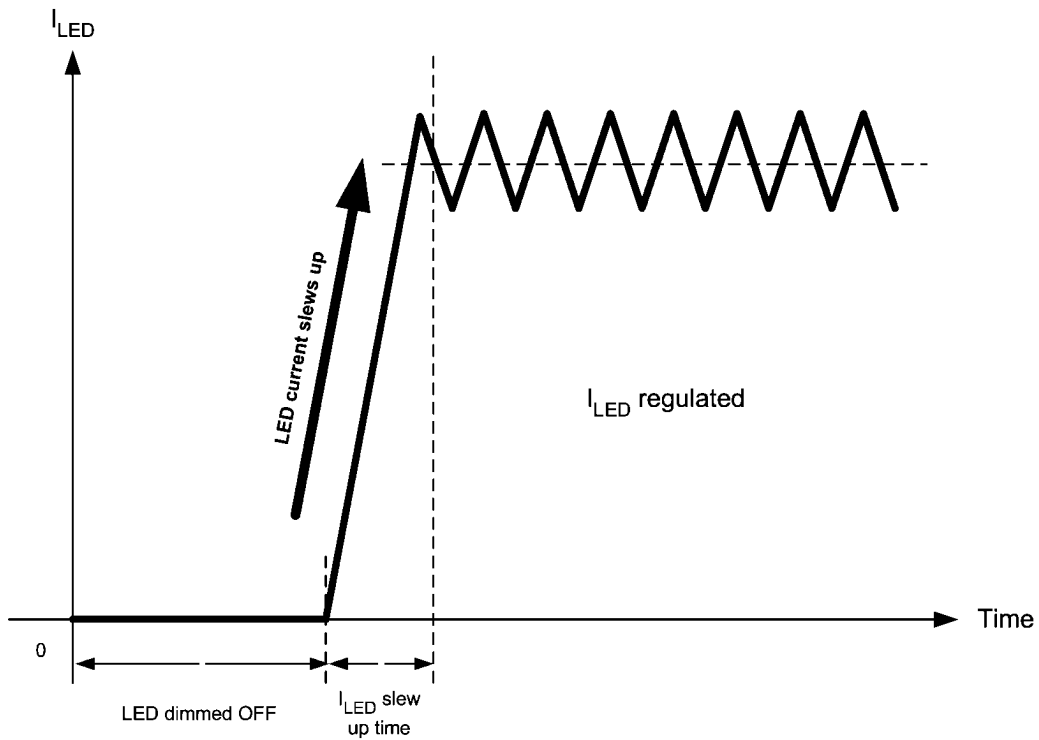

30124825

FIGURE 5. Shortened Current Slew up Time of the LM3414/14HV

To ensure normal operation of the LM3414/14HV, it is recommended to set the dimming frequency not higher than 1/10 of the switching frequency. The minimum dimming duty cycle

is limited by the 400 ns minimum ON time. In applications that require high dimming contrast ratio, low dimming frequency should be used.

ANALOG DIMMING CONTROL

The IADJ pin can be used as an analog dimming signal input. As the average output current of the LM3414 depends on the current being drawn from the IADJ pin, thus the LED current

can be increased or decreased by applying external bias current to the IADJ pin. The simplified circuit diagram for facilitating analog dimming is as shown in figure 6.

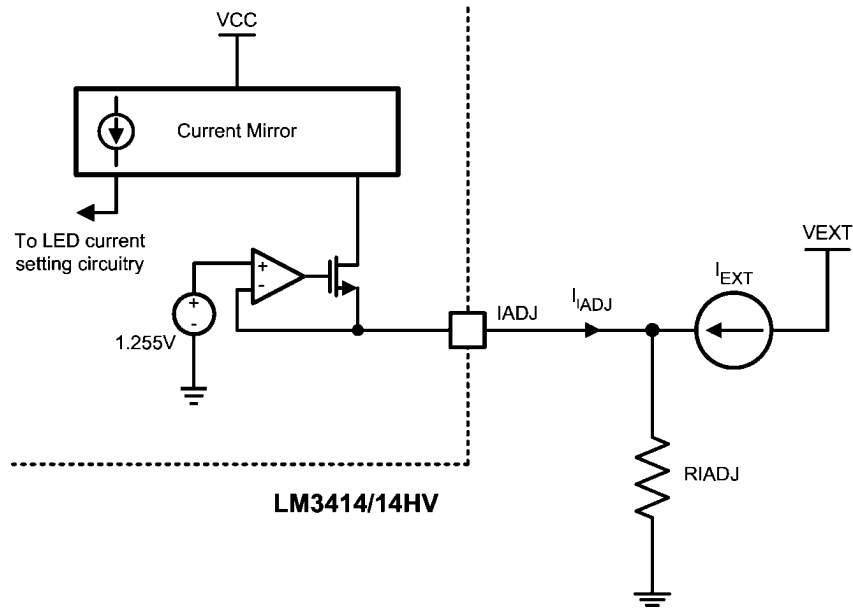

30124826

FIGURE 6. Analog LED Current Control Circuit

When external bias current I_{EXT} is applied to the IADJ pin, the reduction of LED current follows the equations:

$$I_{LED} = \left[\left(\frac{1.255}{R_{IADJ}} - I_{EXT} \right) \times 2490 \times 10^3 \right] \text{ mA}$$

Provided that

$$I_{EXT} < \frac{1.255}{R_{IADJ}}$$

I_{LED} decreases linearly as I_{EXT} increases.

This feature is exceptionally useful for the applications with analog dimming control signals such as those from analog temperature sensors and ambient light sensors.

DESIGN EXAMPLE

Figure 7 shows an example circuit for analog dimming control using simple external biasing circuitry with a variable resistor.

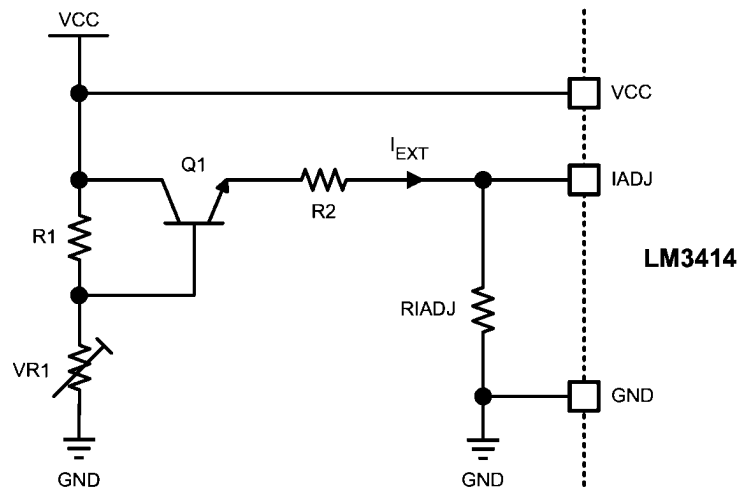

30124827

FIGURE 7. Example Analog Dimming Control Circuit

In the figure, the variable resistor VR1 controls the base voltage of Q1 and eventually adjusts the bias voltage of current to the IADJ pin (I_{EXT}). As the resistance of VR1 increases and the voltage across VR1 exceeds $1.255V + 0.7V$, the LED current starts to decrease as I_{EXT} increases.

where

$$I_{EXT} = \left[\frac{VCC - 1.955 \left(\frac{R1}{VR1} + 1 \right)}{R_2 \left(\frac{R1}{VR1} + 1 \right)} \right] \text{ mA}$$

The analog dimming begins only when $I_{EXT} > 0$.

DESIGN CONSIDERATIONS

The overall performance of the LED driver is highly depends on the PCB layout and component selection. To minimize connection losses and parasitic inductance of the traces, the best practice is to keep the copper traces connecting the inductor, power switch and rectifier short and thick. Long traces on critical power paths will introduce voltage and current spikes to the LM3414/LM3414HV. If the voltage spike level exceeds the absolute maximum pin voltage of the LM3414, it could damage the device and LEDs. To avoid physical damage of the circuit, a Transient Voltage Suppressor (TVS) can be added across VIN and GND pins to suppress the spike voltage. This also helps in absorbing the input voltage spike when the circuit is powered through physical switch upon power up.

Additional Application Circuit

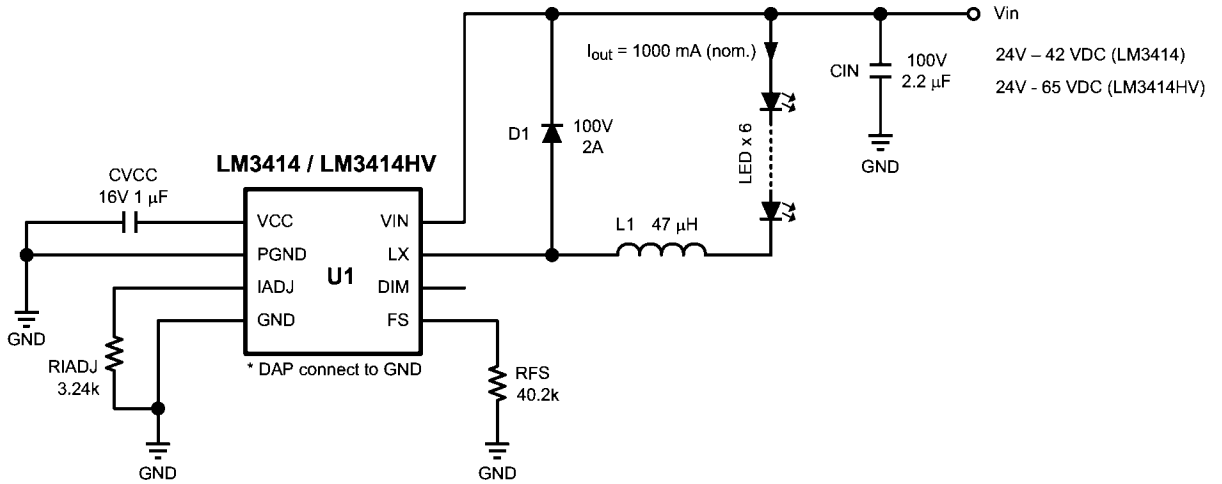

30124828

FIGURE 8. LM3414/14HV Design Example ($I_{OUT} = 500\text{ mA}$)

Bill of Materials

Designation	Description	Package	Manufacture Part #	Vendor
U1	LED Driver IC LM3414 / LM3414HV	ePSOP-8	LM3414 / LM3414HV	NSC
L ₁	Inductor 47 µH	8 x 8 x 4.9 (mm)	MMD-08EZ-470M-SI	Mag.Layers
D ₁	Schottky Diode 100V 2.0A	SMP	SS2PH10-M3	Vishay
C _{IN}	Cap MLCC 100V 2.2 µF X7R	1210	GRM32ER72A225KA35L	Murata
C _{VCC}	Cap MLCC 16V 1.0 µF X5R	603	GRM39X5R105K16D52K	Murata
R _{IADJ}	Chip Resistor 3.24 kΩ 1%	603	CRCW06033241F	Vishay
R _{FS}	Chip Resistor 40.2 kΩ 1%	603	CRCW06034022F	Vishay

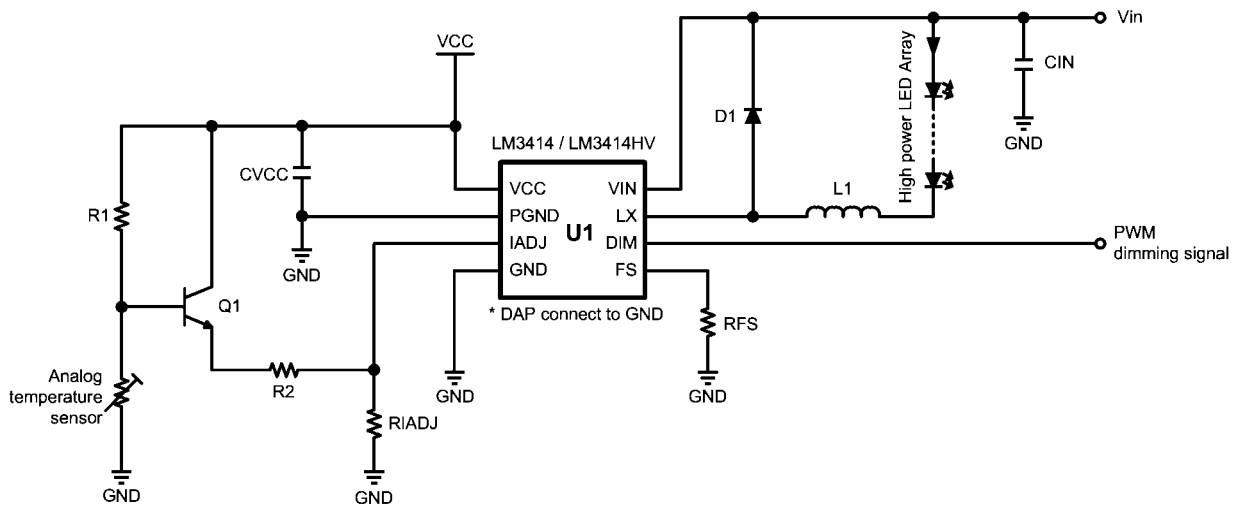

30124829

FIGURE 9. Application Circuit of LM3414/14HV with Temperature Fold-Back Circuitry and PWM Dimming

Physical Dimensions inches (millimeters) unless otherwise noted

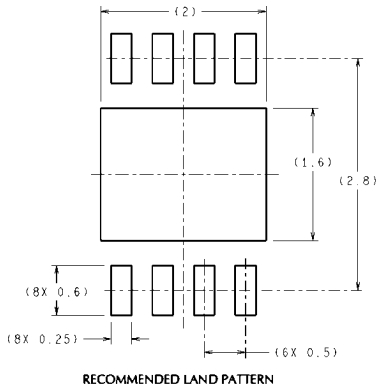

DIMENSIONS ARE IN MILLIMETERS
DIMENSIONS IN () FOR REFERENCE ONLY

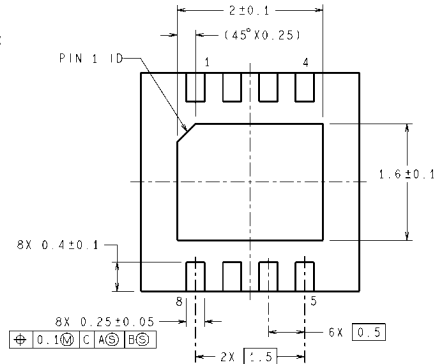
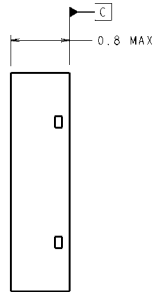
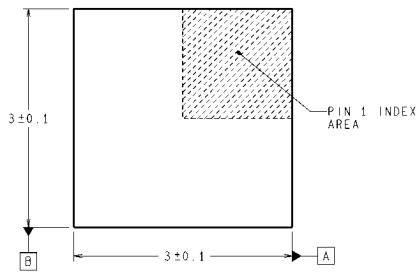
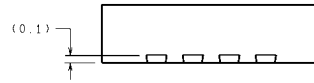

SDA08A (Rev A)

**8-Lead LLP Package
NS Package Number SDA08A**

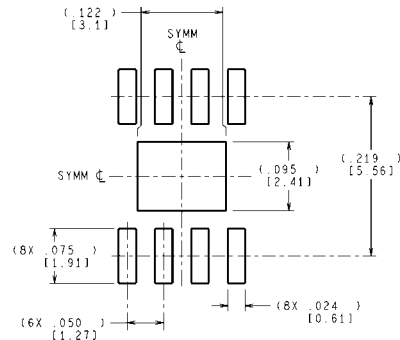
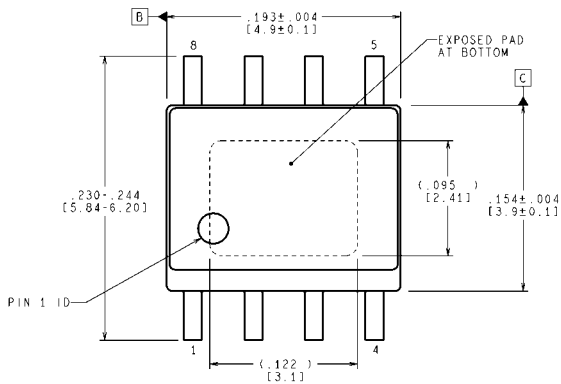

RECOMMENDED LAND PATTERN

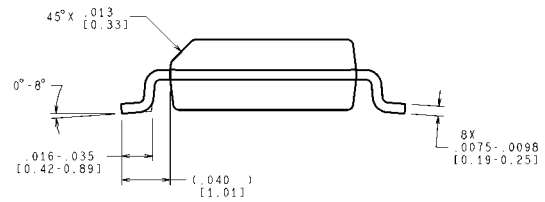
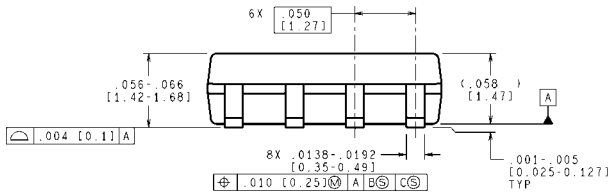

CONTROLLING DIMENSION IS INCH
VALUES IN () ARE MILLIMETERS
DIMENSIONS IN () FOR REFERENCE ONLY

MRA08B (Rev B)

**8-Lead ePSOP Package
NS Package Number MRA08B**