

LM117/LM317A/LM317-N Three-Terminal Adjustable Regulator

Check for Samples: [LM117](#), [LM317A](#), [LM317-N](#)

FEATURES

- **Specified 1% Output Voltage Tolerance (LM317A)**
- **Specified max. 0.01%/V Line Regulation (LM317A)**
- **Specified max. 0.3% Load Regulation (LM117)**
- **Specified 1.5A Output Current**
- **Adjustable Output Down to 1.2V**
- **Current Limit Constant with Temperature**
- **P⁺ Product Enhancement tested**
- **80 dB Ripple Rejection**
- **Output is Short-Circuit Protected**

DESCRIPTION

The LM117 series of adjustable 3-terminal positive voltage regulators is capable of supplying in excess of 1.5A over a 1.2V to 37V output range. They are exceptionally easy to use and require only two external resistors to set the output voltage. Further, both line and load regulation are better than standard fixed regulators. Also, the LM117 is packaged in standard transistor packages which are easily mounted and handled.

In addition to higher performance than fixed regulators, the LM117 series offers full overload protection available only in IC's. Included on the chip are current limit, thermal overload protection and safe area protection. All overload protection circuitry remains fully functional even if the adjustment terminal is disconnected.

Normally, no capacitors are needed unless the device is situated more than 6 inches from the input filter capacitors in which case an input bypass is needed. An optional output capacitor can be added to improve transient response. The adjustment terminal can be bypassed to achieve very high ripple rejection ratios which are difficult to achieve with standard 3-terminal regulators.

Besides replacing fixed regulators, the LM117 is useful in a wide variety of other applications. Since the regulator is "floating" and sees only the input-to-output differential voltage, supplies of several hundred volts can be regulated as long as the maximum input to output differential is not exceeded, i.e., avoid short-circuiting the output.

Also, it makes an especially simple adjustable switching regulator, a programmable output regulator, or by connecting a fixed resistor between the adjustment pin and output, the LM117 can be used as a precision current regulator. Supplies with electronic shutdown can be achieved by clamping the adjustment terminal to ground which programs the output to 1.2V where most loads draw little current.

For applications requiring greater output current, see LM150 series (3A) and LM138 series (5A) data sheets. For the negative complement, see LM137 series data sheet.



Please be aware that an important notice concerning availability, standard warranty, and use in critical applications of Texas Instruments semiconductor products and disclaimers thereto appears at the end of this data sheet.

All trademarks are the property of their respective owners.

Typical Applications

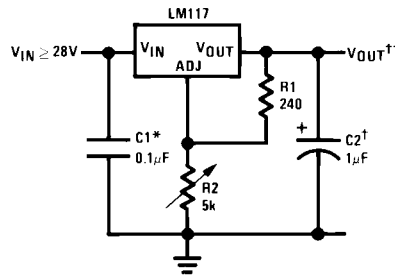

Full output current not available at high input-output voltages

*Needed if device is more than 6 inches from filter capacitors.

†Optional—improves transient response. Output capacitors in the range of 1 μF to 1000 μF of aluminum or tantalum electrolytic are commonly used to provide improved output impedance and rejection of transients.

$$V_{OUT} = 1.25V \left(1 + \frac{R2}{R1} \right) + I_{ADJ}(R2)$$

Figure 1. 1.2V–25V Adjustable Regulator

LM117/LM317A/LM317-N Package Options

Part Number	Package Drawing	Package Type	Output Current
LM117K STEEL	NDS	TO-3	1.5A
LM317K			
LM317AT	NDE	TO-220	
LM317T			
LM317T/LF01	NDG	TO-263	
LM317S	KTT	TO-223	
LM317AEMP	DCY	SOT-223	1.0A
LM317EMP			
LM117H	NDT	TO	0.5A
LM317AH			
LM317H			
LM317AMDT	NDP	TO-252	
LM317MDT			

NOTE

For part numbers that can be ordered, please see the Package Option Addendum at the end of the datasheet.

SOT-223 vs. TO-252 Packages

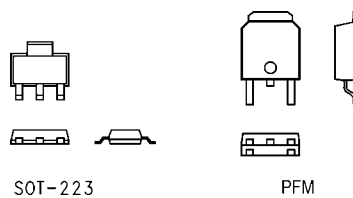
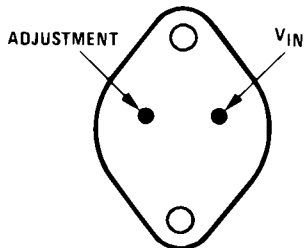

Figure 2. Scale 1:1

Connection Diagrams



CASE IS OUTPUT

**Figure 3. TO-3 (NDS)
Metal Can Package
Bottom View
Package Drawing NDS**

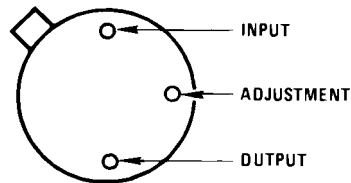

CASE IS OUTPUT

**Figure 4. TO (NDT)
Metal Can Package
Bottom View
Package Drawing NDT**

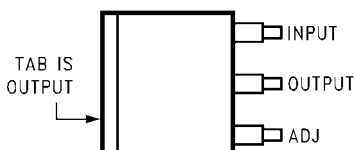

**Figure 5. TO-263 (KTT)
Surface-Mount Package
Top View
Package Drawing KTT**

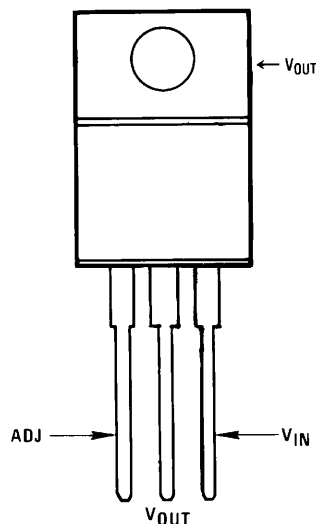

**Figure 6. TO-220 (NDE)
Plastic Package
Front View
Package Drawing NDE**

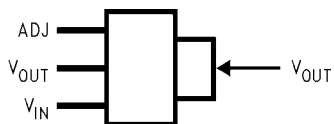

**Figure 7. 4-Lead SOT-223 (DCY)
Top View Surface-Mount Package
Package Number DCY**

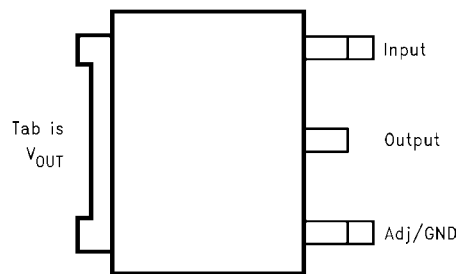

**Figure 8. TO-252 (NDP)
Front View Surface Mount Package
Package Drawing NDP**



These devices have limited built-in ESD protection. The leads should be shorted together or the device placed in conductive foam during storage or handling to prevent electrostatic damage to the MOS gates.

ABSOLUTE MAXIMUM RATINGS ⁽¹⁾⁽²⁾

Power Dissipation		Internally Limited
Input-Output Voltage Differential		+40V, -0.3V
Storage Temperature		-65°C to +150°C
Lead Temperature	Metal Package (Soldering, 10 seconds)	300°C
	Plastic Package (Soldering, 4 seconds)	260°C
ESD Tolerance ⁽³⁾		3 kV

- (1) Absolute Maximum Ratings indicate limits beyond which damage to the device may occur. Operating Ratings indicate conditions for which the device is intended to be functional, but do not ensure specific performance limits. For ensured specifications and test conditions, see the Electrical Characteristics. The ensured specifications apply only for the test conditions listed.
- (2) If Military/Aerospace specified devices are required, please contact the Texas Instruments Sales Office/Distributors for availability and specifications.
- (3) Human body model, 100 pF discharged through a 1.5 kΩ resistor.

OPERATING TEMPERATURE RANGE

LM117		$-55^{\circ}\text{C} \leq T_J \leq +150^{\circ}\text{C}$
LM317A		$-40^{\circ}\text{C} \leq T_J \leq +125^{\circ}\text{C}$
LM317-N		$0^{\circ}\text{C} \leq T_J \leq +125^{\circ}\text{C}$
Preconditioning		
Thermal Limit Burn-In		All Devices 100%

LM117 ELECTRICAL CHARACTERISTICS⁽¹⁾

Specifications with standard type face are for $T_J = 25^\circ\text{C}$, and those with **boldface type** apply over **full Operating Temperature Range**. Unless otherwise specified, $V_{IN} - V_{OUT} = 5\text{V}$, and $I_{OUT} = 10\text{ mA}$.

Parameter	Conditions	LM117 ⁽²⁾				
		Min	Typ	Max	Units	
Reference Voltage	$3\text{V} \leq (V_{IN} - V_{OUT}) \leq 40\text{V}$, $10\text{ mA} \leq I_{OUT} \leq I_{MAX}^{(1)}$	1.20	1.25	1.30	V	
Line Regulation	$3\text{V} \leq (V_{IN} - V_{OUT}) \leq 40\text{V}^{(3)}$		0.01 0.02	0.02 0.05	%/V	
Load Regulation	$10\text{ mA} \leq I_{OUT} \leq I_{MAX}^{(1) (3)}$		0.1 0.3	0.3 1	%	
Thermal Regulation	20 ms Pulse		0.03	0.07	%/W	
Adjustment Pin Current			50	100	μA	
Adjustment Pin Current Change	$10\text{ mA} \leq I_{OUT} \leq I_{MAX}^{(1)}$ $3\text{V} \leq (V_{IN} - V_{OUT}) \leq 40\text{V}$		0.2	5	μA	
Temperature Stability	$T_{MIN} \leq T_J \leq T_{MAX}$		1		%	
Minimum Load Current	$(V_{IN} - V_{OUT}) = 40\text{V}$		3.5	5	mA	
Current Limit	$(V_{IN} - V_{OUT}) \leq 15\text{V}$	NDS Package	1.5	2.2	3.4	A
		NDT Package	0.5	0.8	1.8	
	$(V_{IN} - V_{OUT}) = 40\text{V}$	NDS Package	0.3	0.4		A
		NDT Package	0.15	0.20		
RMS Output Noise, % of V_{OUT}	$10\text{ Hz} \leq f \leq 10\text{ kHz}$		0.003		%	
Ripple Rejection Ratio	$V_{OUT} = 10\text{V}$, $f = 120\text{ Hz}$, $C_{ADJ} = 0\text{ }\mu\text{F}$		65		dB	
	$V_{OUT} = 10\text{V}$, $f = 120\text{ Hz}$, $C_{ADJ} = 10\text{ }\mu\text{F}$	66	80		dB	
Long-Term Stability	$T_J = 125^\circ\text{C}$, 1000 hrs		0.3	1	%	
Thermal Resistance, θ_{JC} Junction-to-Case	NDS (TO-3) Package		2		$^\circ\text{C/W}$	
	NDT (TO) Package		21			
Thermal Resistance, θ_{JA} Junction-to-Ambient (No Heat Sink)	NDS (TO-3) Package		39		$^\circ\text{C/W}$	
	NDT (TO) Package		186			

- (1) $I_{MAX} = 1.5\text{A}$ for the NDS (TO-3), NDE (TO-220), and KTT (TO-263) packages. $I_{MAX} = 1.0\text{A}$ for the DCY (SOT-223) package. $I_{MAX} = 0.5\text{A}$ for the NDT (TO) and NDP (TO-252) packages. Device power dissipation (P_D) is limited by ambient temperature (T_A), device maximum junction temperature (T_J), and package thermal resistance (θ_{JA}). The maximum allowable power dissipation at any temperature is : $P_{D(MAX)} = ((T_{J(MAX)} - T_A)/\theta_{JA})$. All Min. and Max. limits are ensured to TI's Average Outgoing Quality Level (AOQL).
- (2) Specifications and availability for military and space grades of LM117/883 can be found in the LM117QML datasheet ([SNVS356](#)). Specifications and availability for military and space grades of LM117/JAN can be found in the LM117JAN datasheet ([SNVS365](#)).
- (3) Regulation is measured at a constant junction temperature, using pulse testing with a low duty cycle. Changes in output voltage due to heating effects are covered under the specifications for thermal regulation.

LM317A and LM317-N ELECTRICAL CHARACTERISTICS⁽¹⁾

Specifications with standard type face are for $T_J = 25^\circ\text{C}$, and those with **boldface type** apply over **full Operating Temperature Range**. Unless otherwise specified, $V_{IN} - V_{OUT} = 5\text{V}$, and $I_{OUT} = 10\text{ mA}$.

Parameter	Conditions	LM317A			LM317-N			Units	
		Min	Typ	Max	Min	Typ	Max		
Reference Voltage		1.238	1.250	1.262	-	1.25	-	V	
	$3\text{V} \leq (V_{IN} - V_{OUT}) \leq 40\text{V}$, $10\text{ mA} \leq I_{OUT} \leq I_{MAX}^{(1)}$	1.225	1.250	1.270	1.20	1.25	1.30	V	
Line Regulation	$3\text{V} \leq (V_{IN} - V_{OUT}) \leq 40\text{V}^{(2)}$		0.005 0.01	0.01 0.02		0.01 0.02	0.04 0.07	%/V	
Load Regulation	$10\text{ mA} \leq I_{OUT} \leq I_{MAX}^{(1)(2)}$		0.1 0.3	0.5 1		0.1 0.3	0.5 1.5	%	
Thermal Regulation	20 ms Pulse		0.04	0.07		0.04	0.07	%/W	
Adjustment Pin Current			50	100		50	100	μA	
Adjustment Pin Current Change	$10\text{ mA} \leq I_{OUT} \leq I_{MAX}^{(1)}$ $3\text{V} \leq (V_{IN} - V_{OUT}) \leq 40\text{V}$		0.2	5		0.2	5	μA	
Temperature Stability	$T_{MIN} \leq T_J \leq T_{MAX}$		1			1		%	
Minimum Load Current	$(V_{IN} - V_{OUT}) = 40\text{V}$		3.5	10		3.5	10	mA	
Current Limit	$(V_{IN} - V_{OUT}) \leq 15\text{V}$	NDS, KTT Packages	-	-	-	1.5	2.2	3.4	A
		DCY, NDE Packages	1.5	2.2	3.4	1.5	2.2	3.4	
		NDT, MDT Packages	0.5	0.8	1.8	0.5	0.8	1.8	
	$(V_{IN} - V_{OUT}) = 40\text{V}$	NDS, KTT Packages	-	-	-	0.15	0.40		A
		DCY, NDE Packages	0.112	0.30		0.112	0.30		
		NDT, MDT Packages	0.075	0.20		0.075	0.20		
RMS Output Noise, % of V_{OUT}	$10\text{ Hz} \leq f \leq 10\text{ kHz}$		0.003			0.003		%	
Ripple Rejection Ratio	$V_{OUT} = 10\text{V}$, $f = 120\text{ Hz}$, $C_{ADJ} = 0\text{ }\mu\text{F}$		65			65		dB	
	$V_{OUT} = 10\text{V}$, $f = 120\text{ Hz}$, $C_{ADJ} = 10\text{ }\mu\text{F}$	66	80		66	80		dB	
Long-Term Stability	$T_J = 125^\circ\text{C}$, 1000 hrs		0.3	1		0.3	1	%	
Thermal Resistance, θ_{JC} Junction-to-Case	NDS (TO-3) Package		-			2		$^\circ\text{C/W}$	
	NDE (TO-220) Package		4			4			
	KTT (TO-263) Package		-			4			
	DCY (SOT-223) Package		23.5			23.5			
	NDT (TO) Package		21			21			
	NDP (TO-252) Package		12			12			
Thermal Resistance, θ_{JA} Junction-to-Ambient (No Heat Sink)	NDS (TO-3) Package		-			39		$^\circ\text{C/W}$	
	NDE (TO-220) Package		50			50			
	KTT (TO-263) Package ⁽³⁾		-			50			
	DCY (SOT-223) Package ⁽³⁾		140			140			
	NDT (TO) Package		186			186			
	NDP (TO-252) Package ⁽³⁾		103			103			

- $I_{MAX} = 1.5\text{A}$ for the NDS (TO-3), NDE (TO-220), and KTT (TO-263) packages. $I_{MAX} = 1.0\text{A}$ for the DCY (SOT-223) package. $I_{MAX} = 0.5\text{A}$ for the NDT (TO) and NDP (TO-252) packages. Device power dissipation (P_D) is limited by ambient temperature (T_A), device maximum junction temperature (T_J), and package thermal resistance (θ_{JA}). The maximum allowable power dissipation at any temperature is: $P_{D(MAX)} = ((T_{J(MAX)} - T_A)/\theta_{JA})$. All Min. and Max. limits are ensured to TI's Average Outgoing Quality Level (AOQL).
- Regulation is measured at a constant junction temperature, using pulse testing with a low duty cycle. Changes in output voltage due to heating effects are covered under the specifications for thermal regulation.
- When surface mount packages are used (TO-263, SOT-223, TO-252), the junction to ambient thermal resistance can be reduced by increasing the PC board copper area that is thermally connected to the package. See the [APPLICATION HINTS](#) section for heatsink techniques.

TYPICAL PERFORMANCE CHARACTERISTICS

Output Capacitor = 0 μ F unless otherwise noted

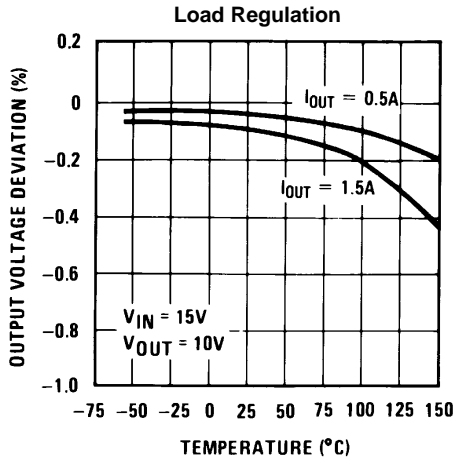

Figure 9.

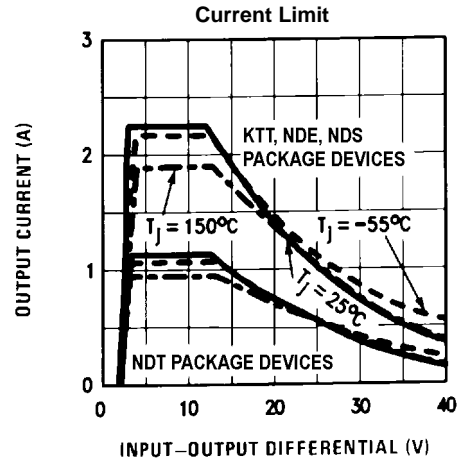

Figure 10.

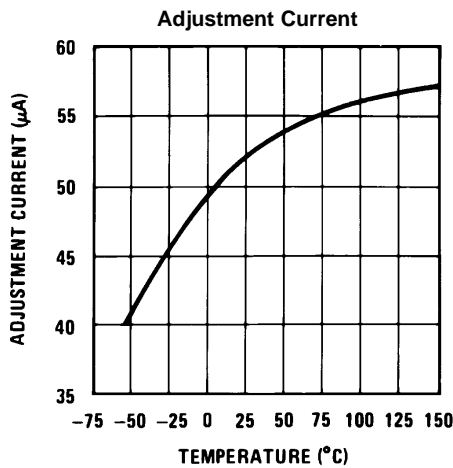

Figure 11.

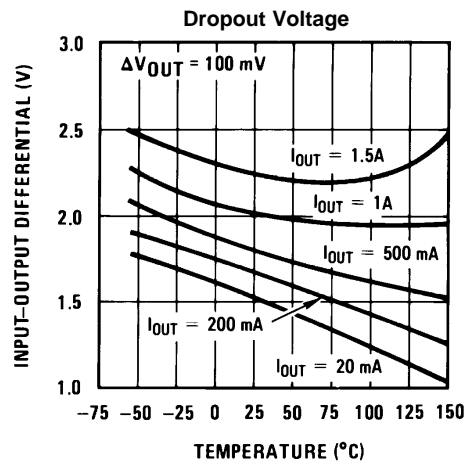

Figure 12.

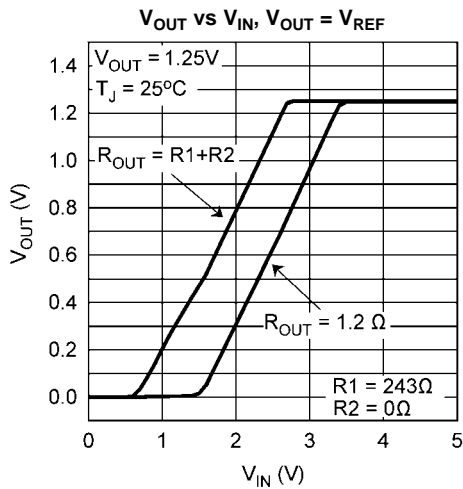

Figure 13.

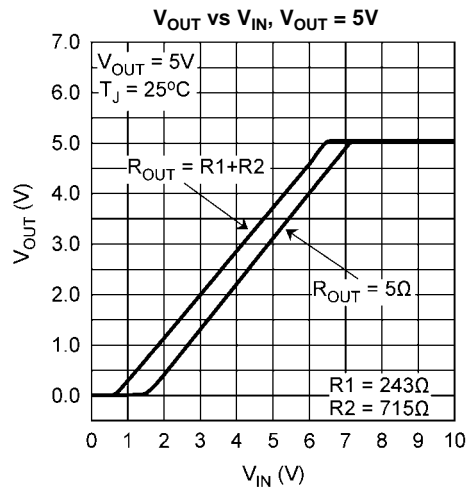

Figure 14.

TYPICAL PERFORMANCE CHARACTERISTICS (continued)

Output Capacitor = 0 μF unless otherwise noted

Temperature Stability

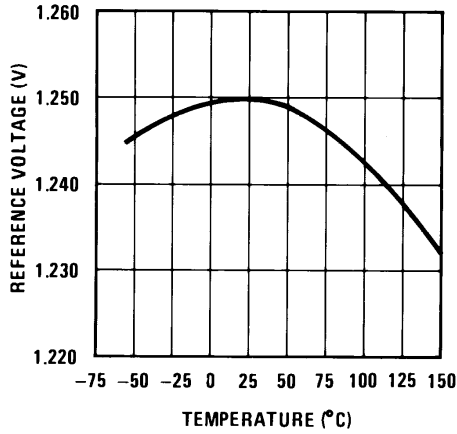

Figure 15.

Minimum Operating Current

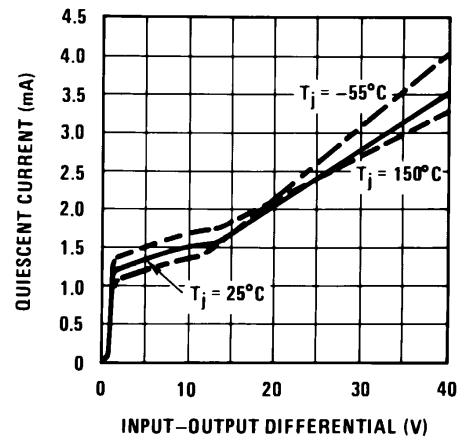

Figure 16.

Ripple Rejection

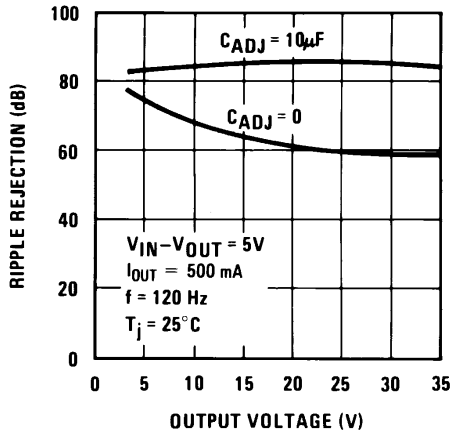

Figure 17.

Ripple Rejection

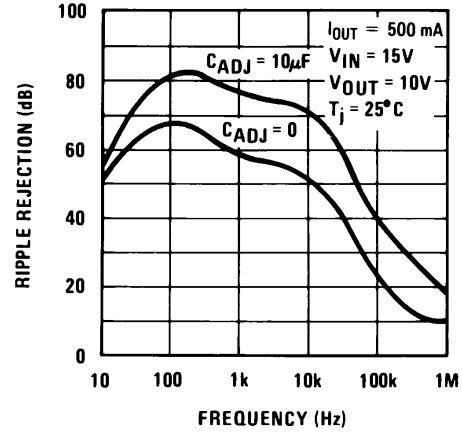

Figure 18.

Ripple Rejection

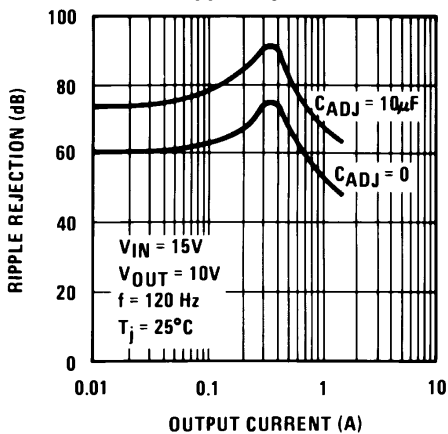

Figure 19.

Output Impedance

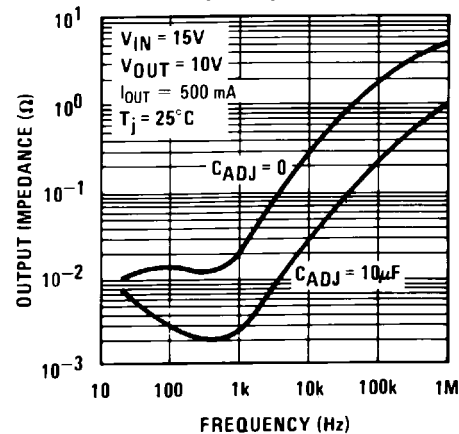

Figure 20.

TYPICAL PERFORMANCE CHARACTERISTICS (continued)

Output Capacitor = 0 μ F unless otherwise noted

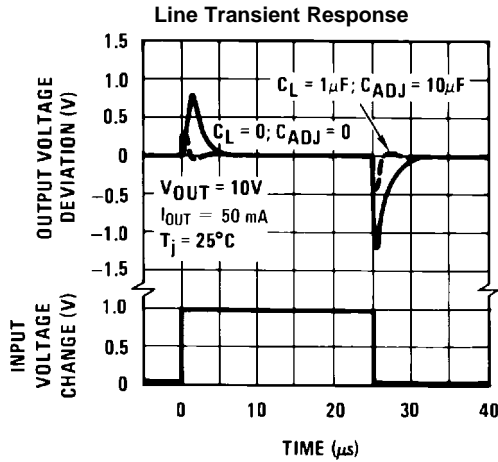

Figure 21.

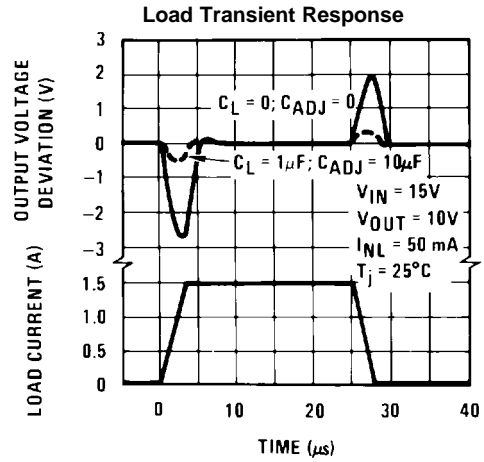
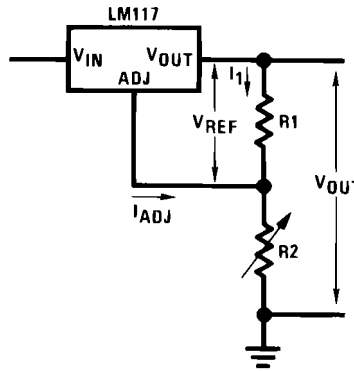

Figure 22.

APPLICATION HINTS

In operation, the LM117 develops a nominal 1.25V reference voltage, V_{REF} , between the output and adjustment terminal. The reference voltage is impressed across program resistor R1 and, since the voltage is constant, a constant current I_1 then flows through the output set resistor R2, giving an output voltage of

$$V_{OUT} = V_{REF} \left(1 + \frac{R_2}{R_1} \right) + I_{ADJ} R_2 \quad (1)$$



Since the 100 μ A current from the adjustment terminal represents an error term, the LM117 was designed to minimize I_{ADJ} and make it very constant with line and load changes. To do this, all quiescent operating current is returned to the output establishing a minimum load current requirement. If there is insufficient load on the output, the output will rise.

External Capacitors

An input bypass capacitor is recommended. A 0.1 μ F disc or 1 μ F solid tantalum on the input is suitable input bypassing for almost all applications. The device is more sensitive to the absence of input bypassing when adjustment or output capacitors are used but the above values will eliminate the possibility of problems.

The adjustment terminal can be bypassed to ground on the LM117 to improve ripple rejection. This bypass capacitor prevents ripple from being amplified as the output voltage is increased. With a 10 μ F bypass capacitor 80 dB ripple rejection is obtainable at any output level. Increases over 10 μ F do not appreciably improve the ripple rejection at frequencies above 120 Hz. If the bypass capacitor is used, it is sometimes necessary to include protection diodes to prevent the capacitor from discharging through internal low current paths and damaging the device.

In general, the best type of capacitors to use is solid tantalum. Solid tantalum capacitors have low impedance even at high frequencies. Depending upon capacitor construction, it takes about 25 μ F in aluminum electrolytic to equal 1 μ F solid tantalum at high frequencies. Ceramic capacitors are also good at high frequencies; but some types have a large decrease in capacitance at frequencies around 0.5 MHz. For this reason, 0.01 μ F disc may seem to work better than a 0.1 μ F disc as a bypass.

Although the LM117 is stable with no output capacitors, like any feedback circuit, certain values of external capacitance can cause excessive ringing. This occurs with values between 500 pF and 5000 pF. A 1 μ F solid tantalum (or 25 μ F aluminum electrolytic) on the output swamps this effect and insures stability. Any increase of the load capacitance larger than 10 μ F will merely improve the loop stability and output impedance.

Load Regulation

The LM117 is capable of providing extremely good load regulation but a few precautions are needed to obtain maximum performance. The current set resistor connected between the adjustment terminal and the output terminal (usually 240 Ω) should be tied directly to the output (case) of the regulator rather than near the load. This eliminates line drops from appearing effectively in series with the reference and degrading regulation. For example, a 15V regulator with 0.05 Ω resistance between the regulator and load will have a load regulation due to line resistance of 0.05 Ω \times I_L . If the set resistor is connected near the load the effective line resistance will be 0.05 Ω (1 + R2/R1) or in this case, 11.5 times worse.

Figure 23 shows the effect of resistance between the regulator and 240 Ω set resistor.

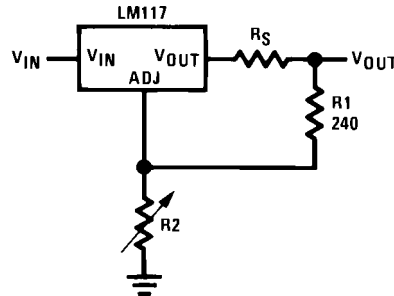

Figure 23. Regulator with Line Resistance in Output Lead

With the TO-3 package, it is easy to minimize the resistance from the case to the set resistor, by using two separate leads to the case. However, with the TO-39 package, care should be taken to minimize the wire length of the output lead. The ground of R2 can be returned near the ground of the load to provide remote ground sensing and improve load regulation.

Protection Diodes

When external capacitors are used with any IC regulator it is sometimes necessary to add protection diodes to prevent the capacitors from discharging through low current points into the regulator. Most 10 μ F capacitors have low enough internal series resistance to deliver 20A spikes when shorted. Although the surge is short, there is enough energy to damage parts of the IC.

When an output capacitor is connected to a regulator and the input is shorted, the output capacitor will discharge into the output of the regulator. The discharge current depends on the value of the capacitor, the output voltage of the regulator, and the rate of decrease of V_{IN} . In the LM117, this discharge path is through a large junction that is able to sustain 15A surge with no problem. This is not true of other types of positive regulators. For output capacitors of 25 μ F or less, there is no need to use diodes.

The bypass capacitor on the adjustment terminal can discharge through a low current junction. Discharge occurs when *either* the input, or the output, is shorted. Internal to the LM117 is a 50 Ω resistor which limits the peak discharge current. No protection is needed for output voltages of 25V or less and 10 μ F capacitance. [Figure 24](#) shows an LM117 with protection diodes included for use with outputs greater than 25V and high values of output capacitance.

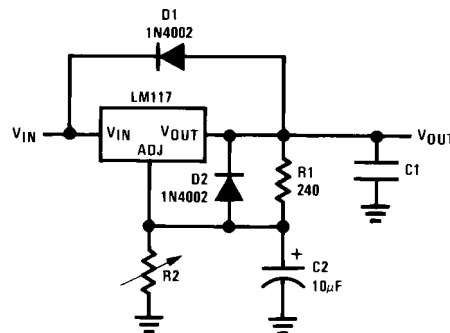

$$V_{OUT} = 1.25V \left(1 + \frac{R_2}{R_1} \right) + I_{ADJ}R_2$$

D1 protects against C1
D2 protects against C2

Figure 24. Regulator with Protection Diodes

Heatsink Requirements

The LM317-N regulators have internal thermal shutdown to protect the device from over-heating. Under all operating conditions, the junction temperature of the LM317-N should not exceed the rated maximum junction temperature (T_J) of 150°C for the LM117, or 125°C for the LM317A and LM317-N. A heatsink may be required depending on the maximum device power dissipation and the maximum ambient temperature of the application. To determine if a heatsink is needed, the power dissipated by the regulator, P_D , must be calculated:

$$P_D = ((V_{IN} - V_{OUT}) \times I_L) + (V_{IN} \times I_G) \quad (2)$$

Figure 25 shows the voltage and currents which are present in the circuit.

The next parameter which must be calculated is the maximum allowable temperature rise, $T_{R(MAX)}$:

$$T_{R(MAX)} = T_{J(MAX)} - T_{A(MAX)} \quad (3)$$

where $T_{J(MAX)}$ is the maximum allowable junction temperature (150°C for the LM117, or 125°C for the LM317A/LM317-N), and $T_{A(MAX)}$ is the maximum ambient temperature which will be encountered in the application.

Using the calculated values for $T_{R(MAX)}$ and P_D , the maximum allowable value for the junction-to-ambient thermal resistance (θ_{JA}) can be calculated:

$$\theta_{JA} = (T_{R(MAX)} / P_D) \quad (4)$$

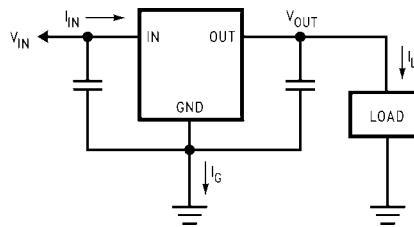

Figure 25. Power Dissipation Diagram

If the calculated maximum allowable thermal resistance is higher than the actual package rating, then no additional work is needed. If the calculated maximum allowable thermal resistance is lower than the actual package rating either the power dissipation (P_D) needs to be reduced, the maximum ambient temperature $T_{A(MAX)}$ needs to be reduced, the thermal resistance (θ_{JA}) must be lowered by adding a heatsink, or some combination of these.

If a heatsink is needed, the value can be calculated from the formula:

$$\theta_{HA} \leq (\theta_{JA} - (\theta_{CH} + \theta_{JC})) \quad (5)$$

where θ_{CH} is the thermal resistance of the contact area between the device case and the heatsink surface, and θ_{JC} is thermal resistance from the junction of the die to surface of the package case.

When a value for $\theta_{(H-A)}$ is found using the equation shown, a heatsink must be selected that has a value that is less than, or equal to, this number.

The $\theta_{(H-A)}$ rating is specified numerically by the heatsink manufacturer in the catalog, or shown in a curve that plots temperature rise vs power dissipation for the heatsink.

Heatsinking Surface Mount Packages

The TO-263 (KTT), SOT-223 (DCY) and TO-252 (NDP) packages use a copper plane on the PCB and the PCB itself as a heatsink. To optimize the heat sinking ability of the plane and PCB, solder the tab of the package to the plane.

Heatsinking the SOT-223 (DCY) Package

Figure 26 and Figure 27 show the information for the SOT-223 package. Figure 27 assumes a $\theta_{(J-A)}$ of 74°C/W for 1 ounce copper and 51°C/W for 2 ounce copper and a maximum junction temperature of 125°C. Please see AN-1028 (literature number [SNVA036](#)) for thermal enhancement techniques to be used with SOT-223 and TO-252 packages.

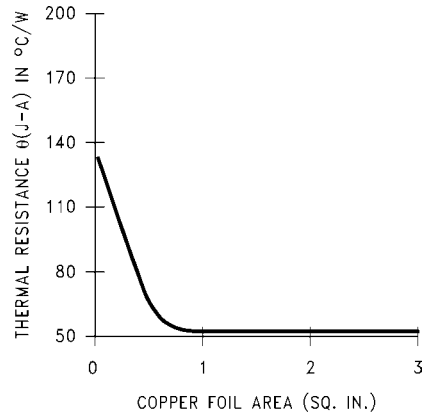

Figure 26. $\theta_{(J-A)}$ vs Copper (2 ounce) Area for the SOT-223 Package

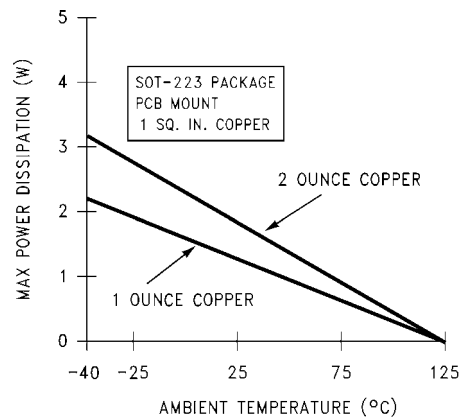

Figure 27. Maximum Power Dissipation vs T_{AMB} for the SOT-223 Package

Heatsinking the TO-263 (KTT) Package

Figure 28 shows for the TO-263 the measured values of $\theta_{(J-A)}$ for different copper area sizes using a typical PCB with 1 ounce copper and no solder mask over the copper area used for heatsinking.

As shown in Figure 28, increasing the copper area beyond 1 square inch produces very little improvement. It should also be observed that the minimum value of $\theta_{(J-A)}$ for the TO-263 package mounted to a PCB is 32°C/W.

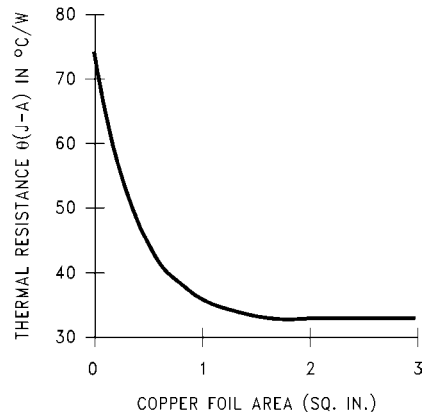

Figure 28. $\theta_{(J-A)}$ vs Copper (1 ounce) Area for the TO-263 Package

As a design aid, [Figure 29](#) shows the maximum allowable power dissipation compared to ambient temperature for the TO-263 device (assuming $\theta_{(J-A)}$ is 35°C/W and the maximum junction temperature is 125°C).

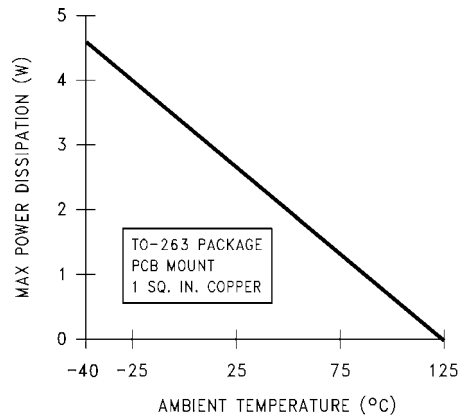

Figure 29. Maximum Power Dissipation vs T_{AMB} for the TO-263 Package

Heatsinking the TO-252 (NDP) Package

If the maximum allowable value for θ_{JA} is found to be $\geq 103^\circ\text{C/W}$ (Typical Rated Value) for the TO-252 package, no heatsink is needed since the package alone will dissipate enough heat to satisfy these requirements. If the calculated value for θ_{JA} falls below these limits, a heatsink is required.

As a design aid, [Table 1](#) shows the value of the θ_{JA} of NDP the package for different heatsink area. The copper patterns that we used to measure these θ_{JA} s are shown in [Figure 34](#). [Figure 30](#) reflects the same test results as what are in [Table 1](#).

[Figure 31](#) shows the maximum allowable power dissipation vs. ambient temperature for the TO-252 device. [Figure 32](#) shows the maximum allowable power dissipation vs. copper area (in²) for the TO-252 device. Please see AN-1028 (literature number [SNVA036](#)) for thermal enhancement techniques to be used with SOT-223 and TO-252 packages.

Table 1. θ_{JA} Different Heatsink Area

Layout	Copper Area		Thermal Resistance (θ_{JA} °C/W) TO-252
	Top Side (in ²) ⁽¹⁾	Bottom Side (in ²)	
1	0.0123	0	103
2	0.066	0	87
3	0.3	0	60
4	0.53	0	54
5	0.76	0	52
6	1.0	0	47
7	0.066	0.2	84
8	0.066	0.4	70
9	0.066	0.6	63
10	0.066	0.8	57
11	0.066	1.0	57
12	0.066	0.066	89
13	0.175	0.175	72
14	0.284	0.284	61
15	0.392	0.392	55
16	0.5	0.5	53

(1) Tab of device attached to topside of copper.

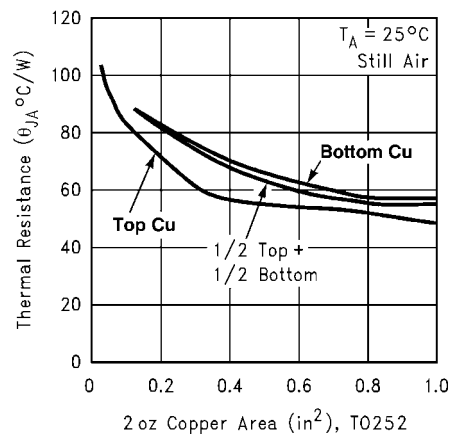

Figure 30. θ_{JA} vs 2oz Copper Area for TO-252

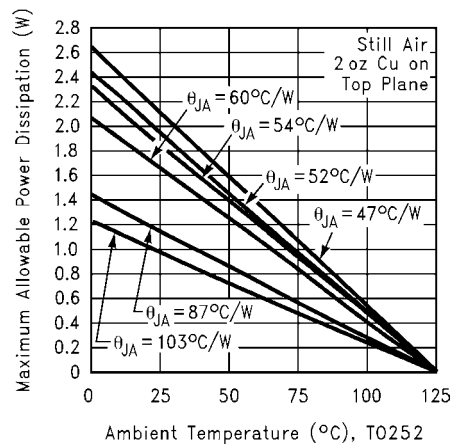

Figure 31. Maximum Allowable Power Dissipation vs. Ambient Temperature for TO-252

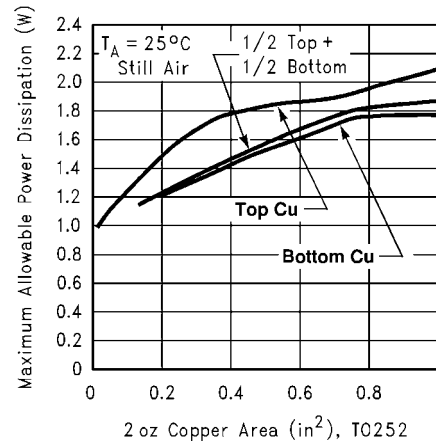

Figure 32. Maximum Allowable Power Dissipation vs. 2oz Copper Area for TO-252

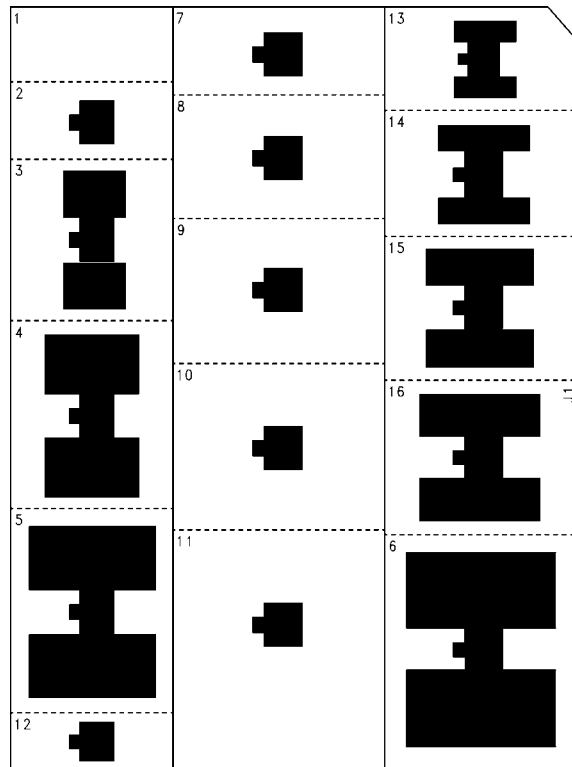

Figure 33. Top View of the Thermal Test Pattern in Actual Scale

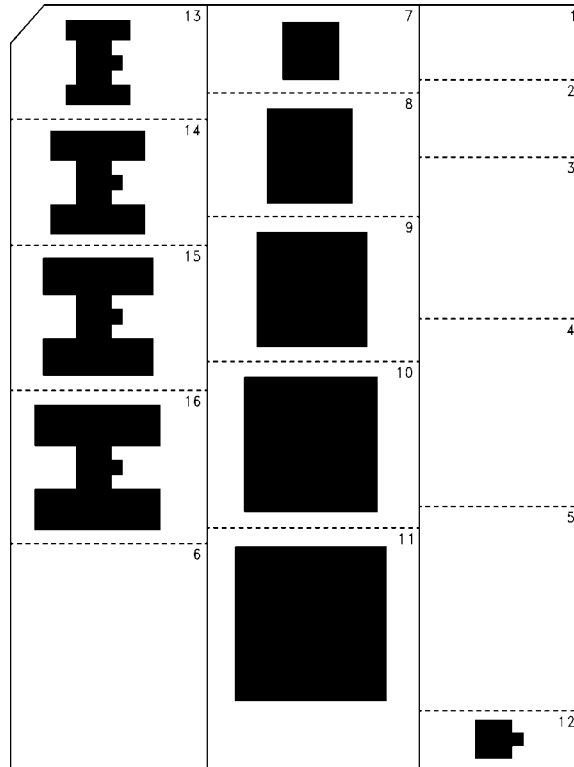
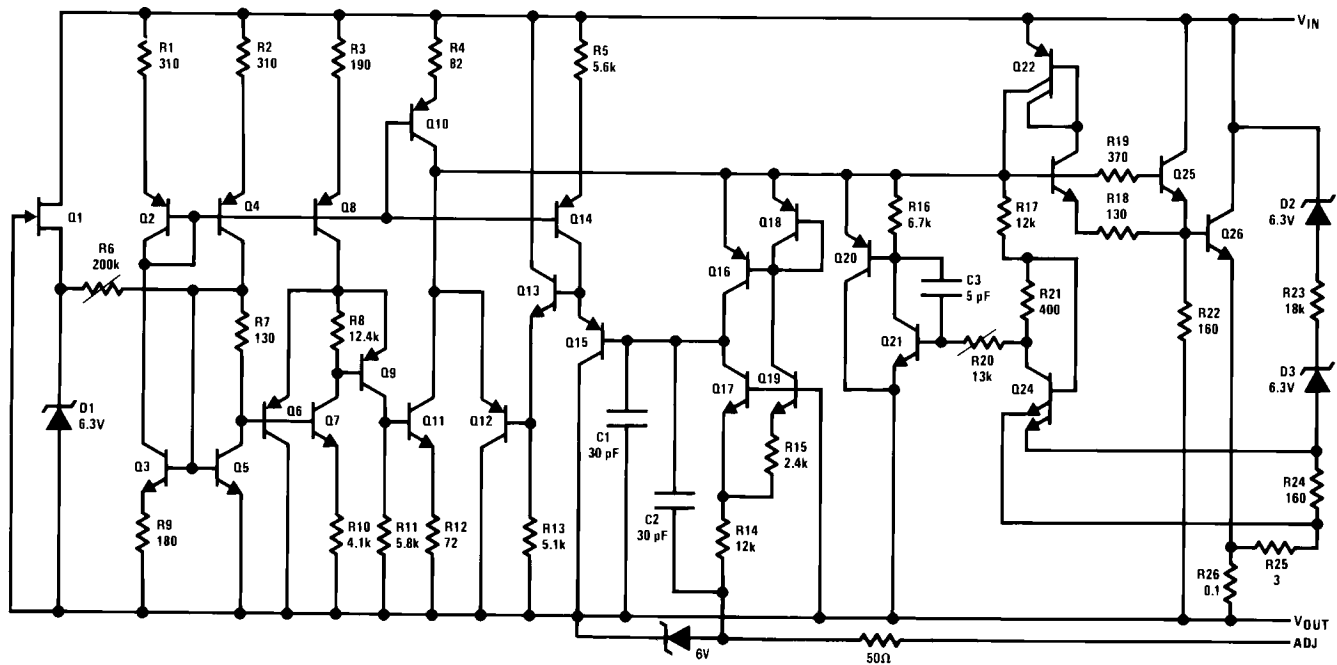
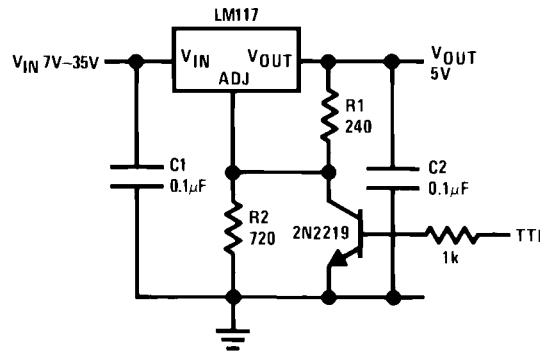

Figure 34. Bottom View of the Thermal Test Pattern in Actual Scale

Schematic Diagram



Typical Applications



NOTE: Min. output \cong 1.2V

Figure 35. 5V Logic Regulator with Electronic Shutdown

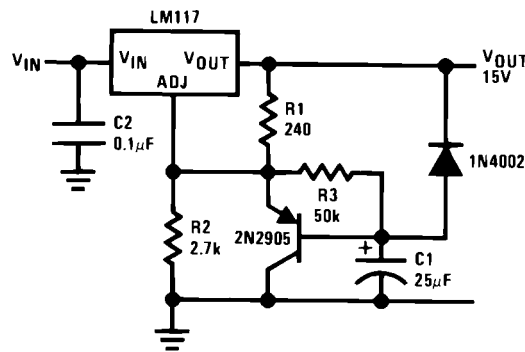
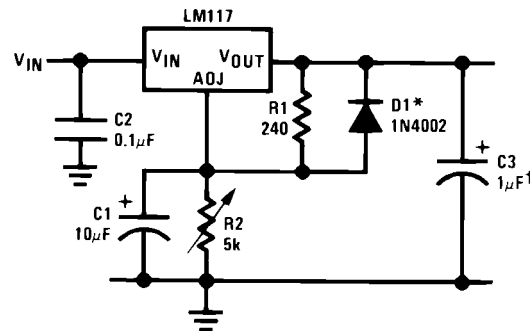

Figure 36. Slow Turn-On 15V Regulator



†Solid tantalum

*Discharges C1 if output is shorted to ground

Figure 37. Adjustable Regulator with Improved Ripple Rejection

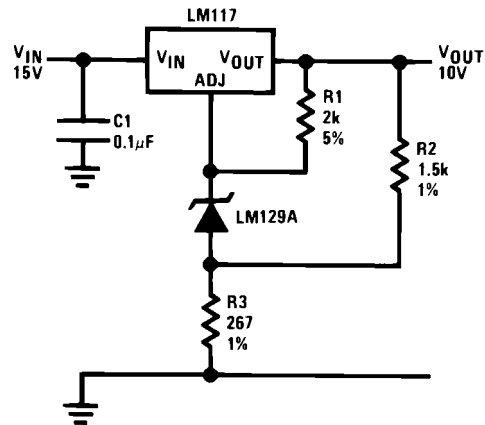
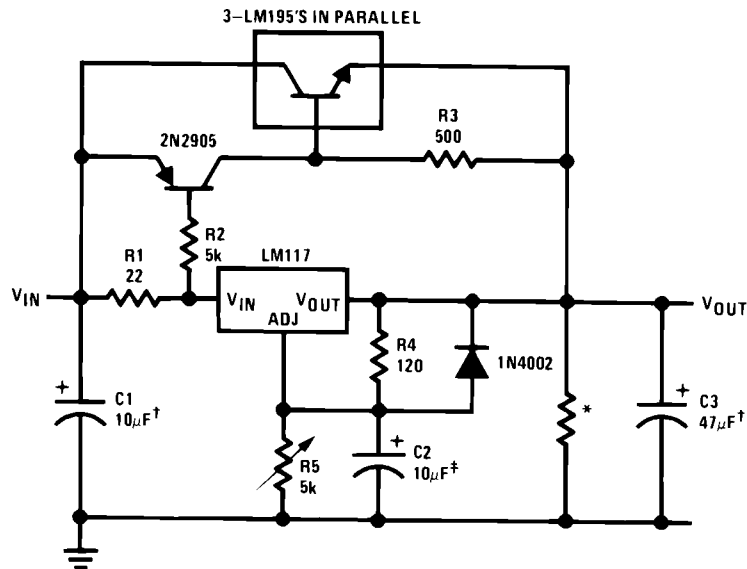
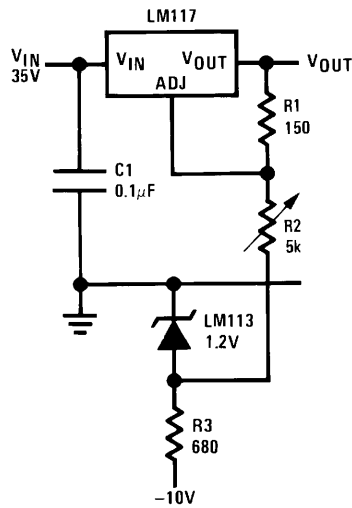

Figure 38. High Stability 10V Regulator



‡Optional—improves ripple rejection
 †Solid tantalum
 *Minimum load current = 30 mA

Figure 39. High Current Adjustable Regulator



Full output current not available at high input-output voltages

Figure 40. 0 to 30V Regulator

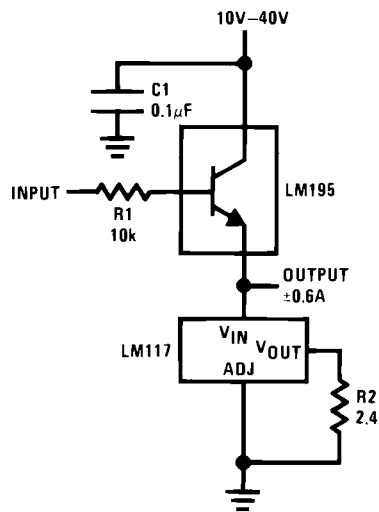
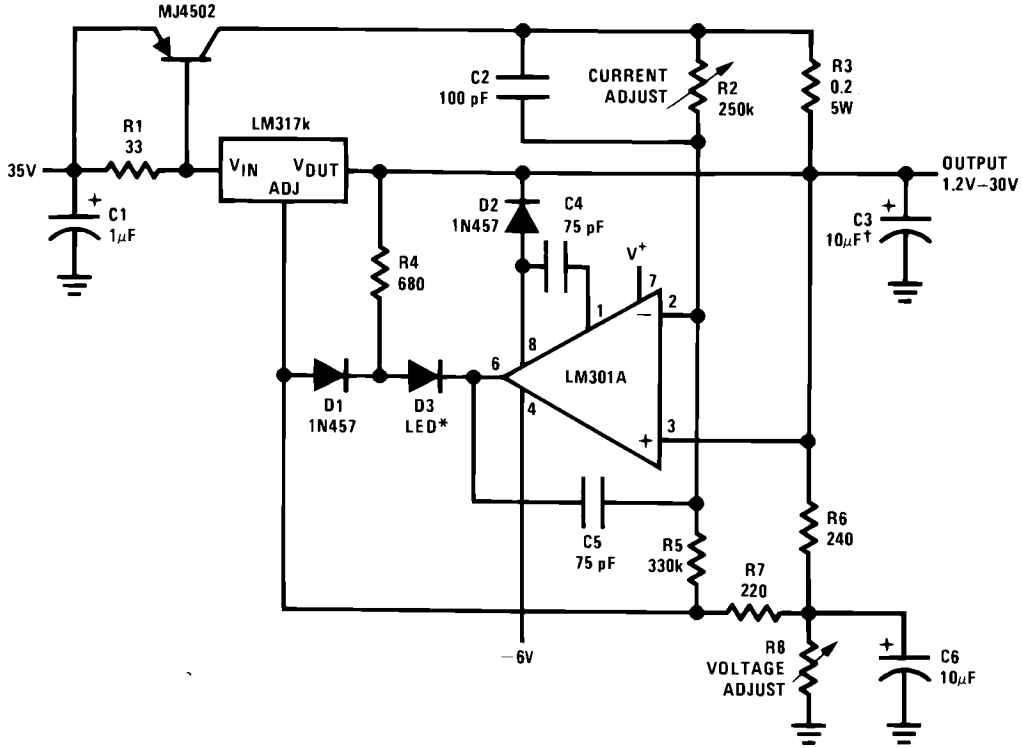

Figure 41. Power Follower



†Solid tantalum

*Lights in constant current mode

Figure 42. 5A Constant Voltage/Constant Current Regulator

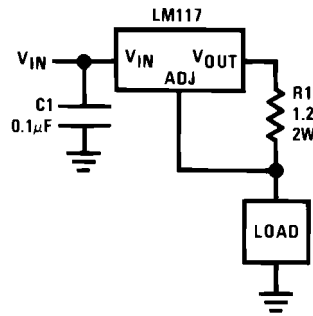
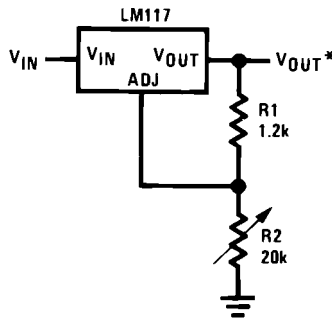

Figure 43. 1A Current Regulator



*Minimum load current \approx 4 mA

Figure 44. 1.2V–20V Regulator with Minimum Program Current

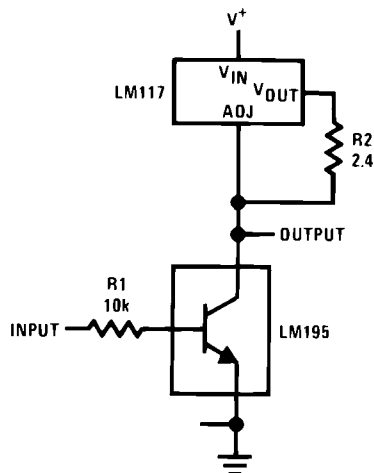
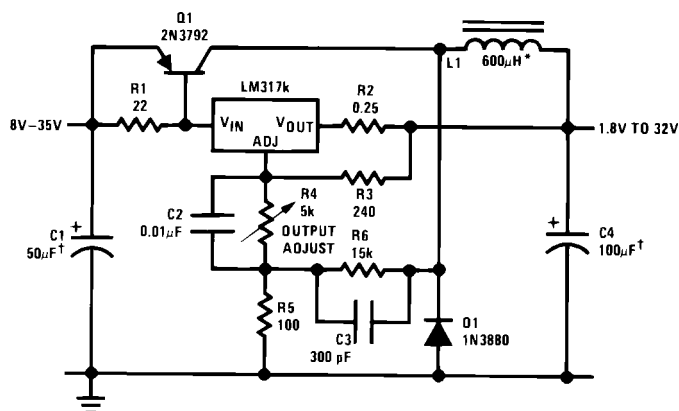

Figure 45. High Gain Amplifier



†Solid tantalum

*Core—Arnold A-254168-2 60 turns

Figure 46. Low Cost 3A Switching Regulator

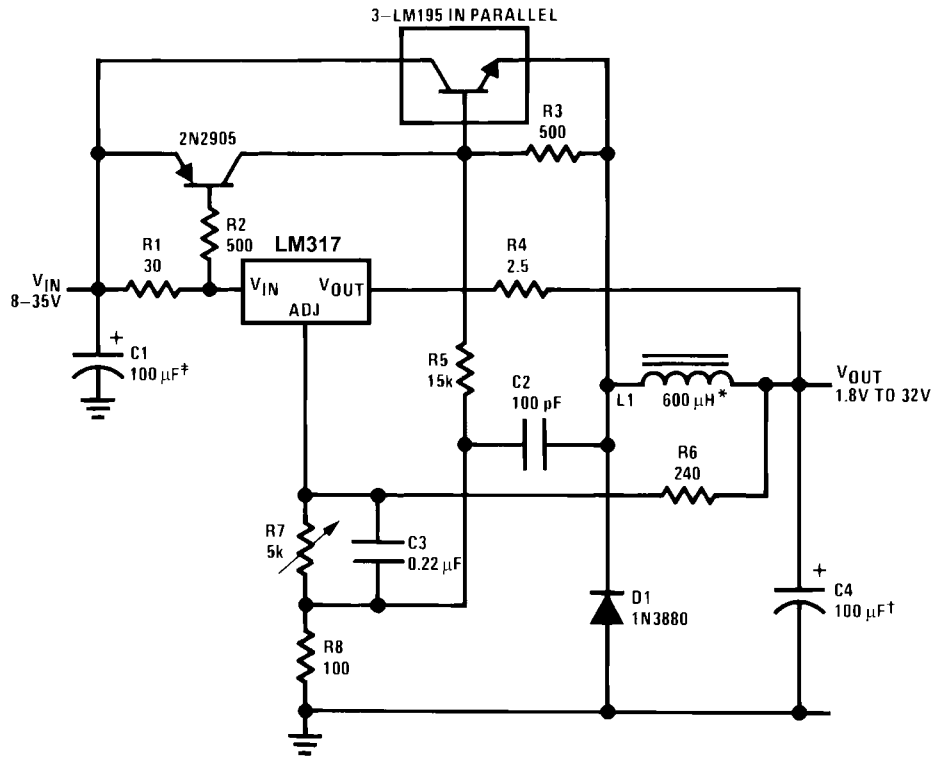

†Solid tantalum

*Core—Arnold A-254168-2 60 turns

Figure 47. 4A Switching Regulator with Overload Protection

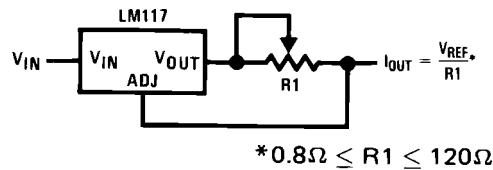

Figure 48. Precision Current Limiter

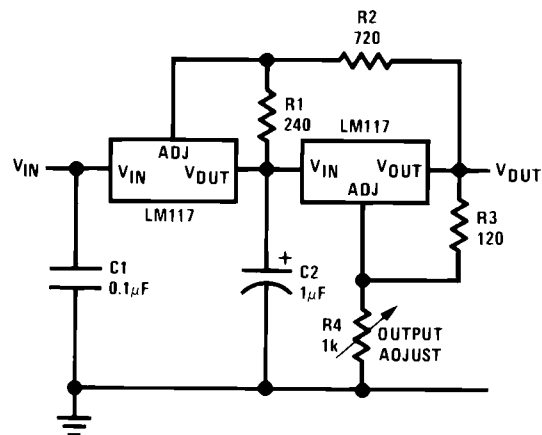
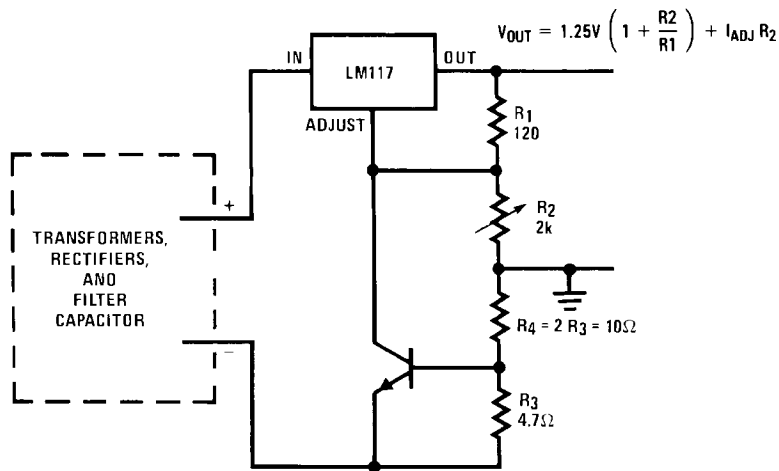

Figure 49. Tracking Preregulator



—Short circuit current is approximately $\frac{600 \text{ mV}}{R_3}$, or 120 mA

(Compared to LM117's higher current limit)

—At 50 mA output only $\frac{3}{4}$ volt of drop occurs in R_3 and R_4

Figure 50. Current Limited Voltage Regulator

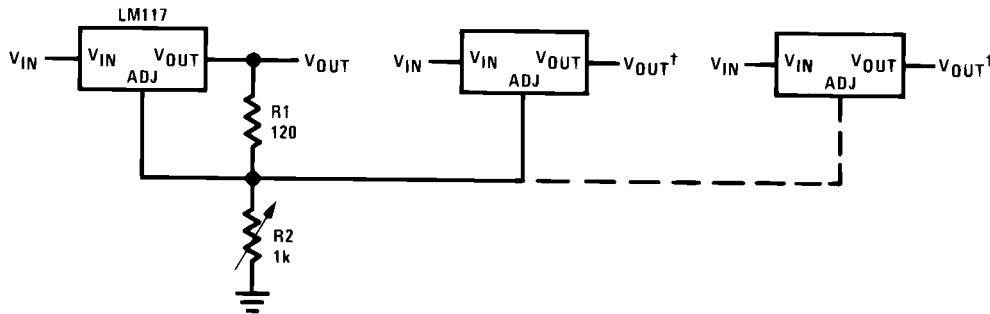

*All outputs within $\pm 100 \text{ mV}$

†Minimum load—10 mA

Figure 51. Adjusting Multiple On-Card Regulators with Single Control*

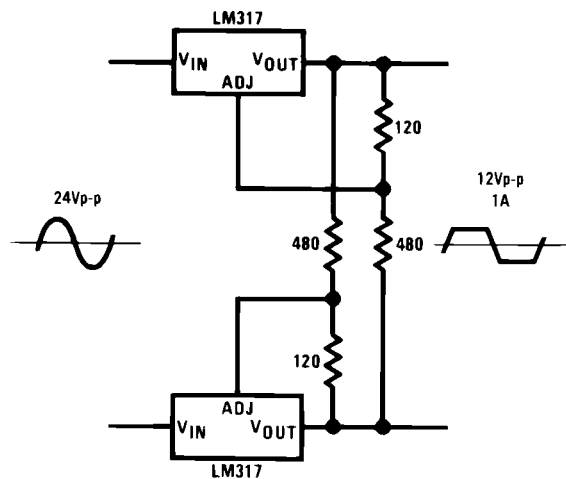
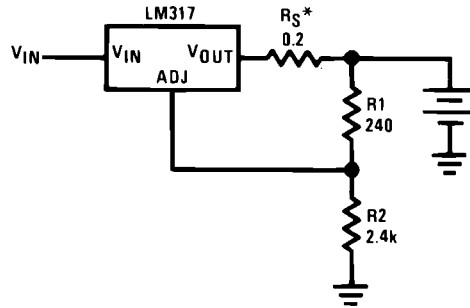

Figure 52. AC Voltage Regulator



* R_S —sets output impedance of charger: $Z_{OUT} = R_S \left(1 + \frac{R_2}{R_1} \right)$

Use of R_S allows low charging rates with fully charged battery.

Figure 53. 12V Battery Charger

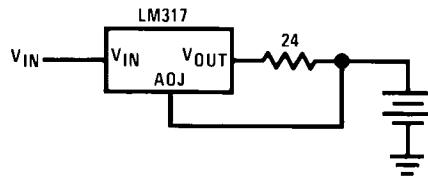

Figure 54. 50mA Constant Current Battery Charger

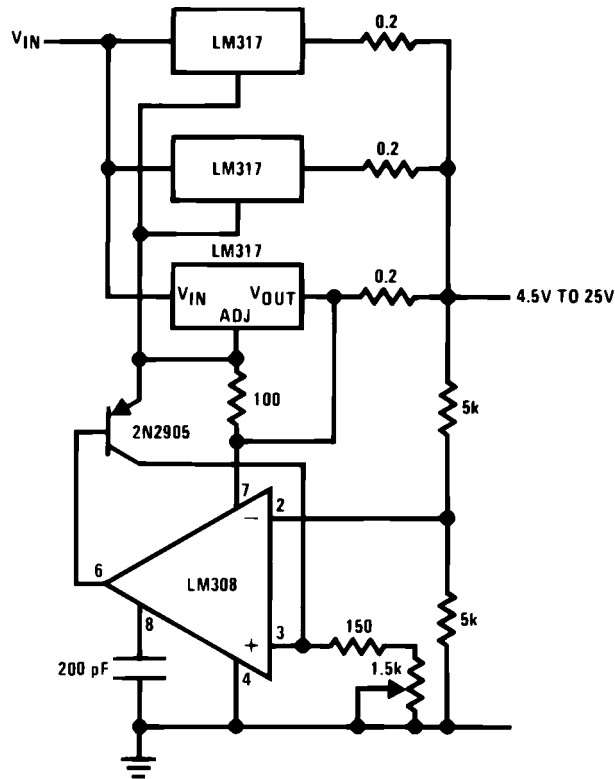
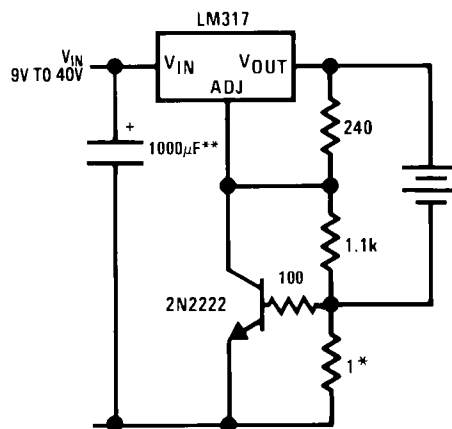

Figure 55. Adjustable 4A Regulator



*Sets peak current (0.6A for 1Ω)

**The 1000µF is recommended to filter out input transients

Figure 56. Current Limited 6V Charger

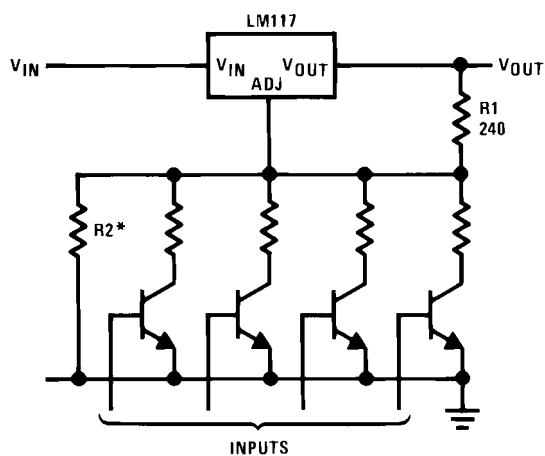

*Sets maximum V_{OUT}

Figure 57. Digitally Selected Outputs

PACKAGING INFORMATION

Orderable Device	Status (1)	Package Type	Package Drawing	Pins	Package Qty	Eco Plan (2)	Lead/Ball Finish	MSL Peak Temp (3)	Op Temp (°C)	Device Marking (4/5)	Samples
LM117H	ACTIVE	TO	NDT	3	500	Green (RoHS & no Sb/Br)	AU	Level-1-NA-UNLIM	-55 to 125	LM117HP+	Samples
LM117H/NOPB	ACTIVE	TO	NDT	3	500	Green (RoHS & no Sb/Br)	AU	Level-1-NA-UNLIM	-55 to 125	LM117HP+	Samples
LM117K STEEL	ACTIVE	TO-3	NDS	2	50	TBD	Call TI	Call TI	-55 to 125	LM117K STEELP+	Samples
LM117K STEEL/NOPB	ACTIVE	TO-3	NDS	2	50	Green (RoHS & no Sb/Br)	POST-PLATE	Level-1-NA-UNLIM	-55 to 125	LM117K STEELP+	Samples
LM317AEMP	ACTIVE	SOT-223	DCY	4	1000	TBD	Call TI	Call TI	-40 to 125	N07A	Samples
LM317AEMP/NOPB	ACTIVE	SOT-223	DCY	4	1000	Green (RoHS & no Sb/Br)	CU SN	Level-1-260C-UNLIM	-40 to 125	N07A	Samples
LM317AEMPX	ACTIVE	SOT-223	DCY	4	2000	TBD	Call TI	Call TI		N07A	Samples
LM317AEMPX/NOPB	ACTIVE	SOT-223	DCY	4	2000	Green (RoHS & no Sb/Br)	CU SN	Level-1-260C-UNLIM	-40 to 125	N07A	Samples
LM317AH	ACTIVE	TO	NDT	3	500	Green (RoHS & no Sb/Br)	AU	Level-1-NA-UNLIM	-40 to 125	LM317AHP+	Samples
LM317AH/NOPB	ACTIVE	TO	NDT	3	500	Green (RoHS & no Sb/Br)	AU	Level-1-NA-UNLIM	-40 to 125	LM317AHP+	Samples
LM317AMDT	ACTIVE	TO-252	NDP	3	75	TBD	Call TI	Call TI	-40 to 125	LM317 AMDT	Samples
LM317AMDT/NOPB	ACTIVE	TO-252	NDP	3	75	Green (RoHS & no Sb/Br)	CU SN	Level-2-260C-1 YEAR	-40 to 125	LM317 AMDT	Samples
LM317AMDTX	ACTIVE	TO-252	NDP	3	2500	TBD	Call TI	Call TI	-40 to 125	LM317 AMDT	Samples
LM317AMDTX/NOPB	ACTIVE	TO-252	NDP	3	2500	Green (RoHS & no Sb/Br)	CU SN	Level-2-260C-1 YEAR	-40 to 125	LM317 AMDT	Samples
LM317AT	ACTIVE	TO-220	NDE	3	45	TBD	Call TI	Call TI	-40 to 125	LM317AT P+	Samples
LM317AT/NOPB	ACTIVE	TO-220	NDE	3	45	Pb-Free (RoHS Exempt)	CU SN	Level-1-NA-UNLIM	-40 to 125	LM317AT P+	Samples
LM317EMP	ACTIVE	SOT-223	DCY	4	1000	TBD	Call TI	Call TI	0 to 125	N01A	Samples
LM317EMP/NOPB	ACTIVE	SOT-223	DCY	4	1000	Green (RoHS & no Sb/Br)	CU SN	Level-1-260C-UNLIM	0 to 125	N01A	Samples

Orderable Device	Status (1)	Package Type	Package Drawing	Pins	Package Qty	Eco Plan (2)	Lead/Ball Finish	MSL Peak Temp (3)	Op Temp (°C)	Device Marking (4/5)	Samples
LM317EMPX/NOPB	ACTIVE	SOT-223	DCY	4	2000	Green (RoHS & no Sb/Br)	CU SN	Level-1-260C-UNLIM	0 to 125	N01A	Samples
LM317H	ACTIVE	TO	NDT	3	500	Green (RoHS & no Sb/Br)	AU	Level-1-NA-UNLIM	0 to 125	LM317HP+	Samples
LM317H/NOPB	ACTIVE	TO	NDT	3	500	Green (RoHS & no Sb/Br)	AU	Level-1-NA-UNLIM	0 to 125	LM317HP+	Samples
LM317K STEEL	ACTIVE	TO-3	NDS	2	50	TBD	Call TI	Call TI	0 to 125	LM317K STEELP+	Samples
LM317K STEEL/NOPB	ACTIVE	TO-3	NDS	2	50	Green (RoHS & no Sb/Br)	POST-PLATE	Level-1-NA-UNLIM	0 to 125	LM317K STEELP+	Samples
LM317MDT/NOPB	ACTIVE	TO-252	NDP	3	75	Green (RoHS & no Sb/Br)	CU SN	Level-2-260C-1 YEAR	0 to 125	LM317 MDT	Samples
LM317MDTX/NOPB	ACTIVE	TO-252	NDP	3	2500	Green (RoHS & no Sb/Br)	CU SN	Level-2-260C-1 YEAR	0 to 125	LM317 MDT	Samples
LM317S/NOPB	ACTIVE	DDPAK/ TO-263	KTT	3	45	Pb-Free (RoHS Exempt)	CU SN	Level-3-245C-168 HR	0 to 125	LM317S P+	Samples
LM317SX/NOPB	ACTIVE	DDPAK/ TO-263	KTT	3	500	Pb-Free (RoHS Exempt)	CU SN	Level-3-245C-168 HR	0 to 125	LM317S P+	Samples
LM317T	ACTIVE	TO-220	NDE	3	45	TBD	Call TI	Call TI		LM317T P+	Samples
LM317T/LF01	ACTIVE	TO-220	NDG	3	45	Pb-Free (RoHS Exempt)	CU SN	Level-4-260C-72 HR		LM317T P+	Samples
LM317T/NOPB	ACTIVE	TO-220	NDE	3	45	Green (RoHS & no Sb/Br)	CU SN	Level-1-NA-UNLIM	0 to 125	LM317T P+	Samples

(1) The marketing status values are defined as follows:

ACTIVE: Product device recommended for new designs.

LIFEBUY: TI has announced that the device will be discontinued, and a lifetime-buy period is in effect.

NRND: Not recommended for new designs. Device is in production to support existing customers, but TI does not recommend using this part in a new design.

PREVIEW: Device has been announced but is not in production. Samples may or may not be available.

OBSELETE: TI has discontinued the production of the device.

(2) Eco Plan - The planned eco-friendly classification: Pb-Free (RoHS), Pb-Free (RoHS Exempt), or Green (RoHS & no Sb/Br) - please check <http://www.ti.com/productcontent> for the latest availability information and additional product content details.

TBD: The Pb-Free/Green conversion plan has not been defined.

Pb-Free (RoHS): TI's terms "Lead-Free" or "Pb-Free" mean semiconductor products that are compatible with the current RoHS requirements for all 6 substances, including the requirement that lead not exceed 0.1% by weight in homogeneous materials. Where designed to be soldered at high temperatures, TI Pb-Free products are suitable for use in specified lead-free processes.

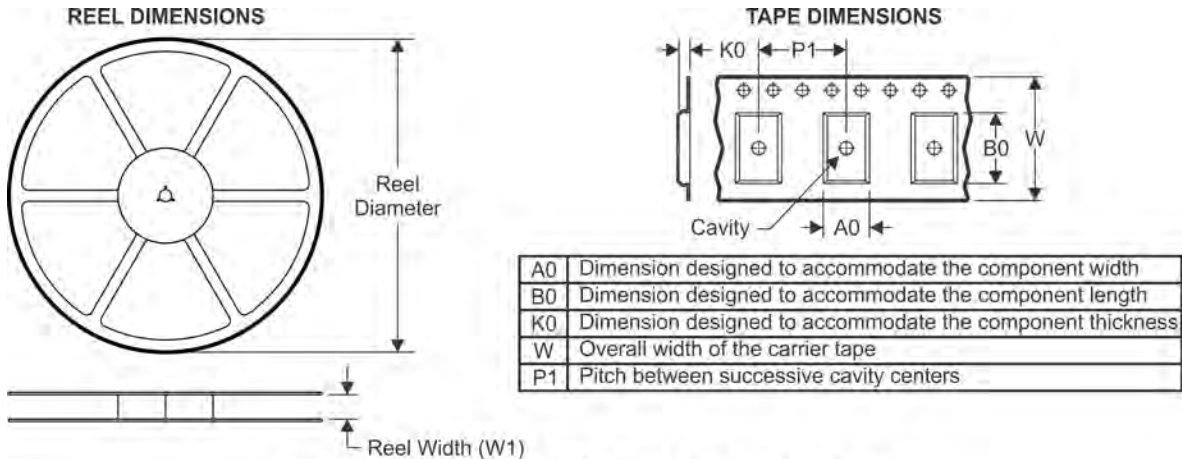
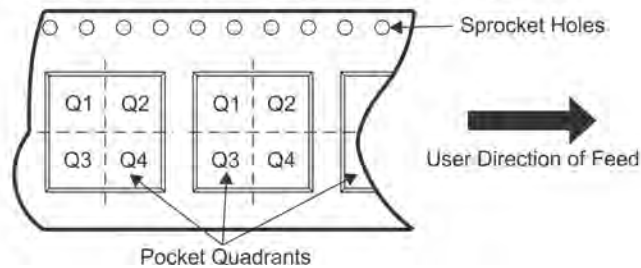
TAPE AND REEL INFORMATION

QUADRANT ASSIGNMENTS FOR PIN 1 ORIENTATION IN TAPE

*All dimensions are nominal

Device	Package Type	Package Drawing	Pins	SPQ	Reel Diameter (mm)	Reel Width W1 (mm)	A0 (mm)	B0 (mm)	K0 (mm)	P1 (mm)	W (mm)	Pin1 Quadrant
LM317AEMP	SOT-223	DCY	4	1000	330.0	16.4	7.0	7.5	2.2	12.0	16.0	Q3
LM317AEMP/NOPB	SOT-223	DCY	4	1000	330.0	16.4	7.0	7.5	2.2	12.0	16.0	Q3
LM317AEMPX	SOT-223	DCY	4	2000	330.0	16.4	7.0	7.5	2.2	12.0	16.0	Q3
LM317AEMPX/NOPB	SOT-223	DCY	4	2000	330.0	16.4	7.0	7.5	2.2	12.0	16.0	Q3
LM317AMDTX	TO-252	NDP	3	2500	330.0	16.4	6.9	10.5	2.7	8.0	16.0	Q2
LM317AMDTX/NOPB	TO-252	NDP	3	2500	330.0	16.4	6.9	10.5	2.7	8.0	16.0	Q2
LM317EMP	SOT-223	DCY	4	1000	330.0	16.4	7.0	7.5	2.2	12.0	16.0	Q3
LM317EMP/NOPB	SOT-223	DCY	4	1000	330.0	16.4	7.0	7.5	2.2	12.0	16.0	Q3
LM317EMPX/NOPB	SOT-223	DCY	4	2000	330.0	16.4	7.0	7.5	2.2	12.0	16.0	Q3
LM317MDTX/NOPB	TO-252	NDP	3	2500	330.0	16.4	6.9	10.5	2.7	8.0	16.0	Q2
LM317SX/NOPB	DDPAK/ TO-263	KTT	3	500	330.0	24.4	10.75	14.85	5.0	16.0	24.0	Q2

TAPE AND REEL BOX DIMENSIONS

*All dimensions are nominal

Device	Package Type	Package Drawing	Pins	SPQ	Length (mm)	Width (mm)	Height (mm)
LM317AEMP	SOT-223	DCY	4	1000	367.0	367.0	35.0
LM317AEMP/NOPB	SOT-223	DCY	4	1000	367.0	367.0	35.0
LM317AEMPX	SOT-223	DCY	4	2000	367.0	367.0	35.0
LM317AEMPX/NOPB	SOT-223	DCY	4	2000	367.0	367.0	35.0
LM317AMDTX	TO-252	NDP	3	2500	367.0	367.0	35.0
LM317AMDTX/NOPB	TO-252	NDP	3	2500	367.0	367.0	38.0
LM317EMP	SOT-223	DCY	4	1000	367.0	367.0	35.0
LM317EMP/NOPB	SOT-223	DCY	4	1000	367.0	367.0	35.0
LM317EMPX/NOPB	SOT-223	DCY	4	2000	367.0	367.0	35.0
LM317MDTX/NOPB	TO-252	NDP	3	2500	367.0	367.0	38.0
LM317SX/NOPB	DDPAK/TO-263	KTT	3	500	367.0	367.0	45.0

NDT0003A

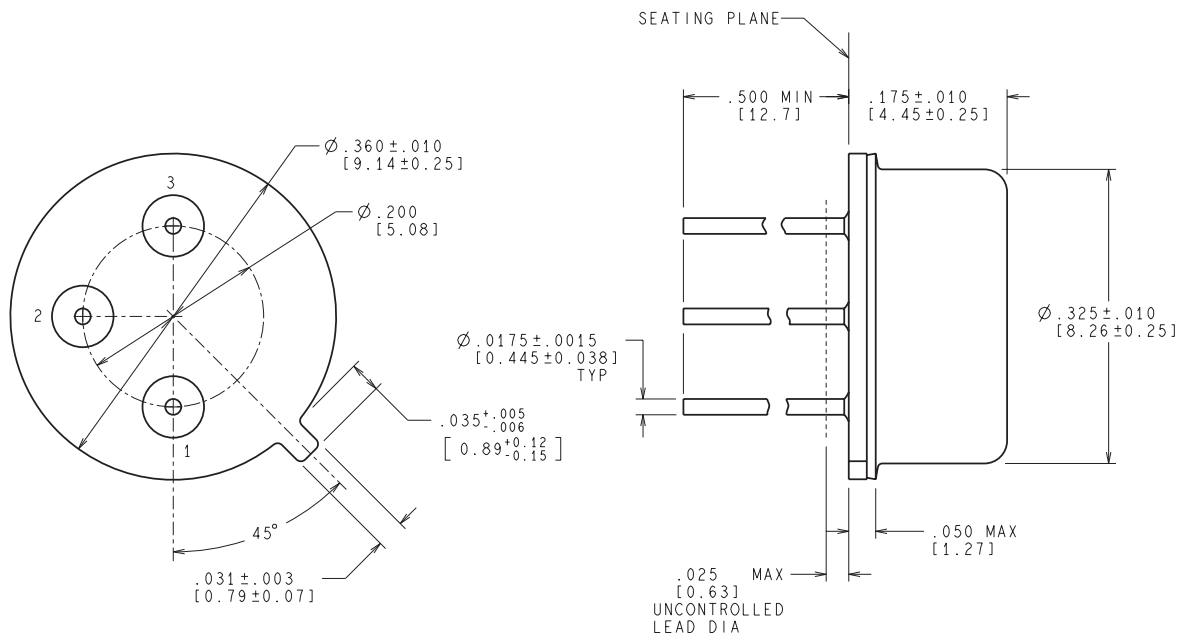

CONTROLLING DIMENSION IS INCH
VALUES IN [] ARE MILLIMETERS

MIL-PRF-38535
CONFIGURATION CONTROL

H03A (Rev D)

NDS0002A

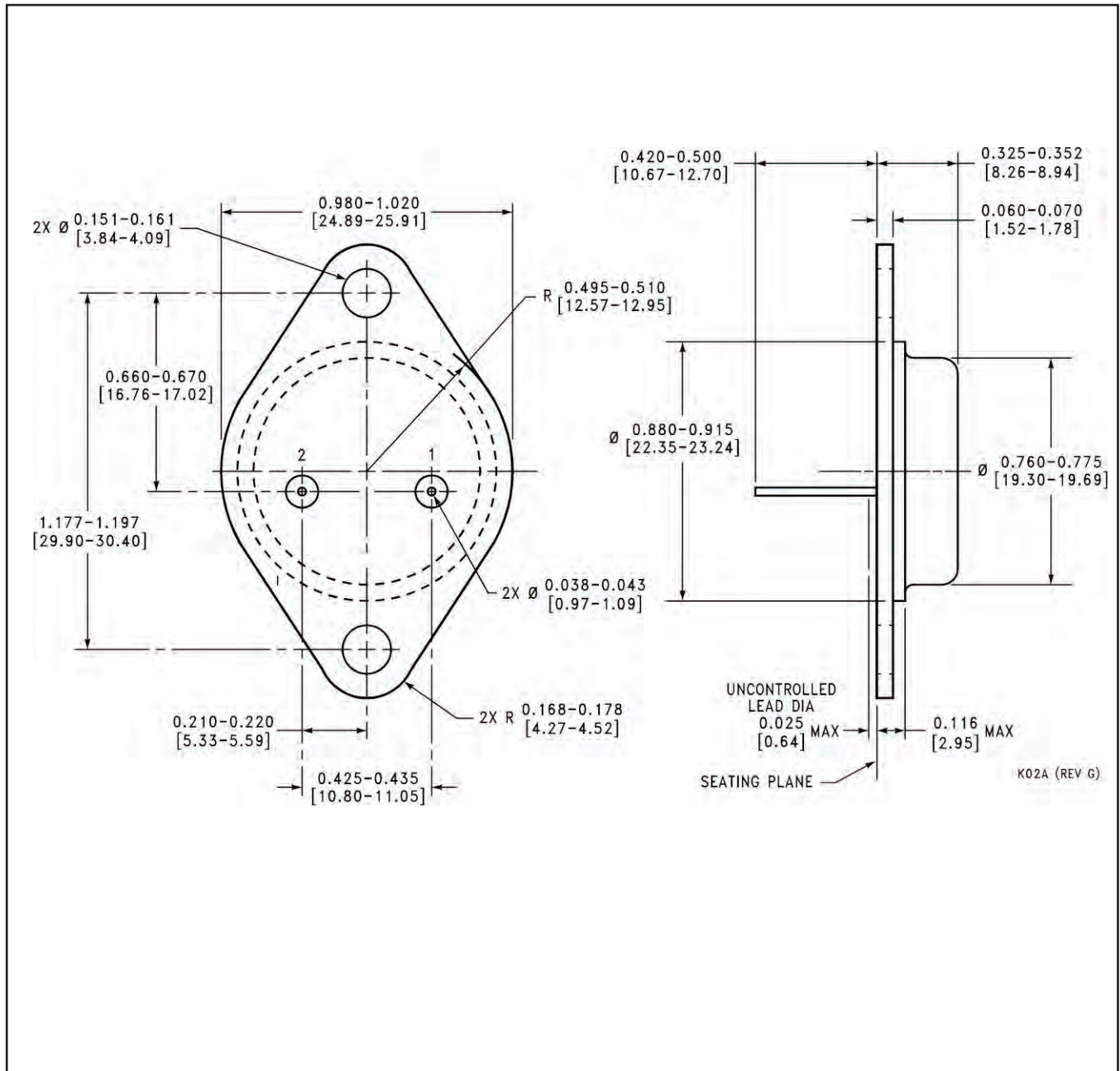

NDE0003B

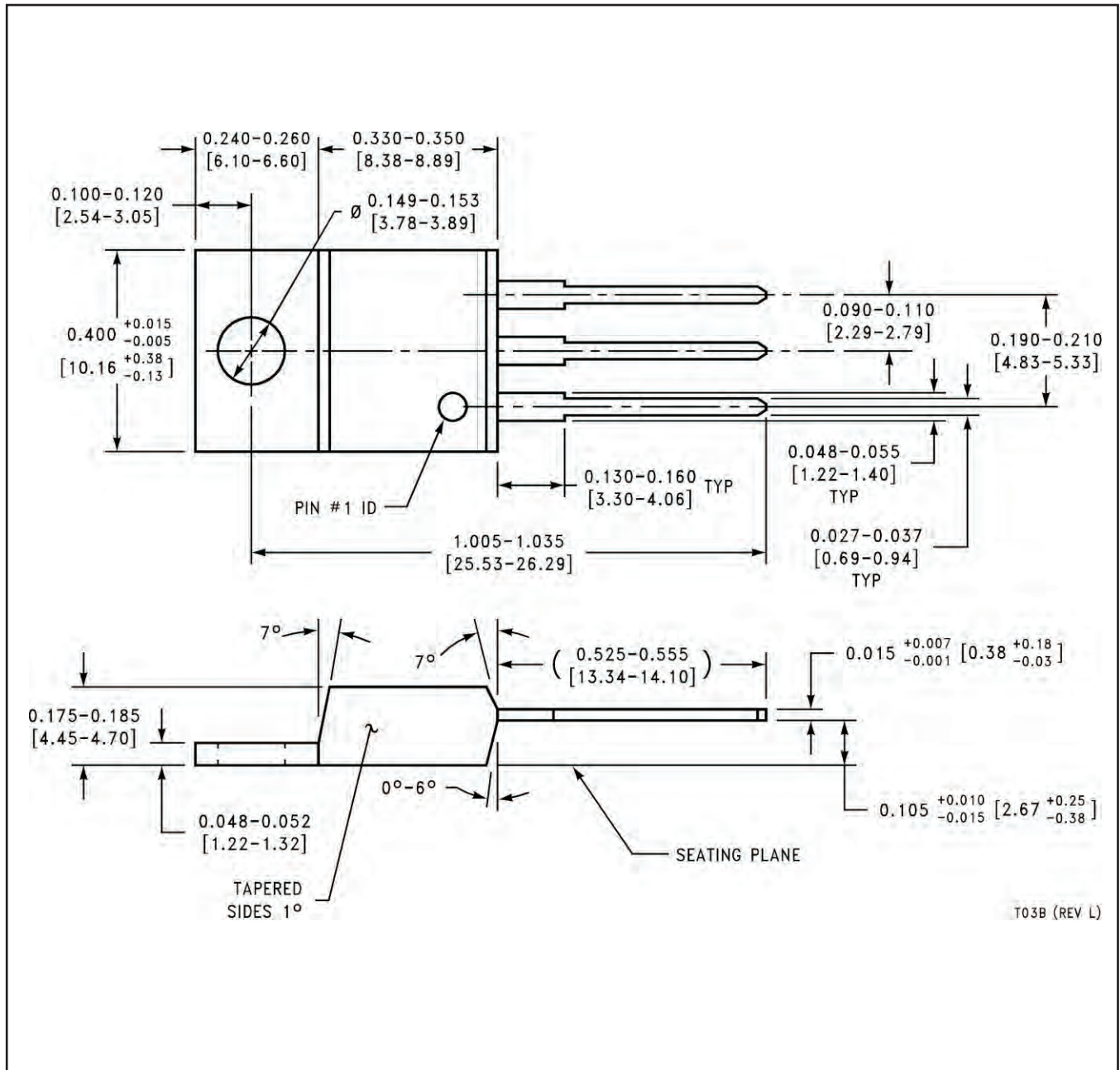

MECHANICAL DATA

NDG0003F

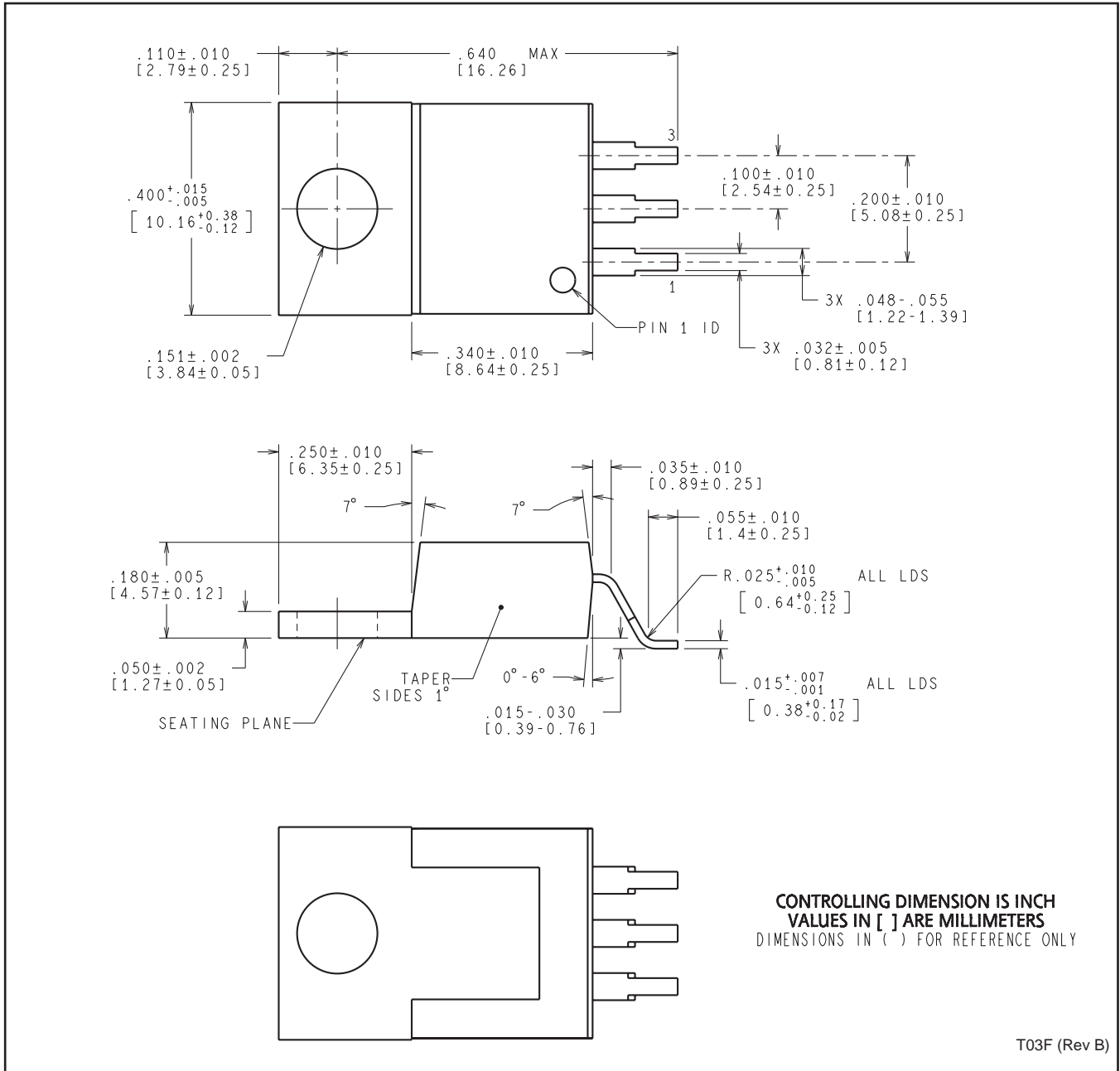

T03F (Rev B)

NDP0003B

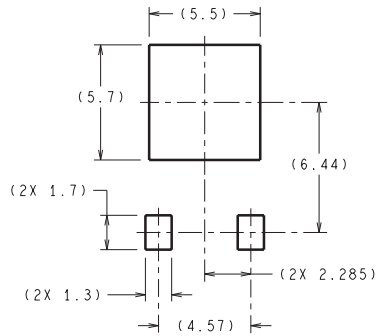

DIMENSIONS ARE IN MILLIMETERS
DIMENSIONS IN () FOR REFERENCE ONLY

LAND PATTERN RECOMMENDATION

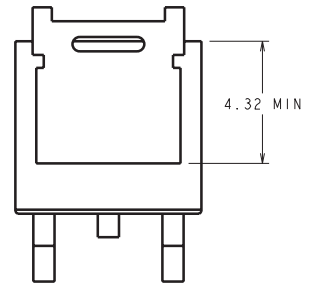
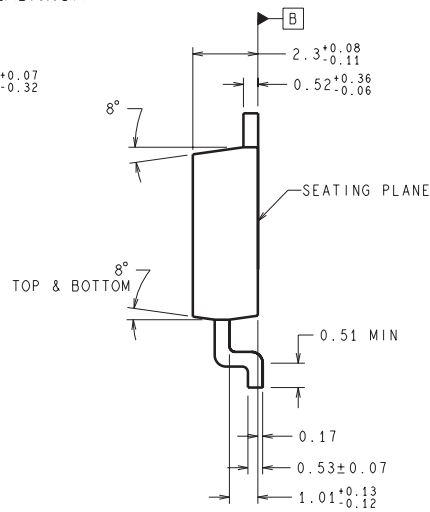
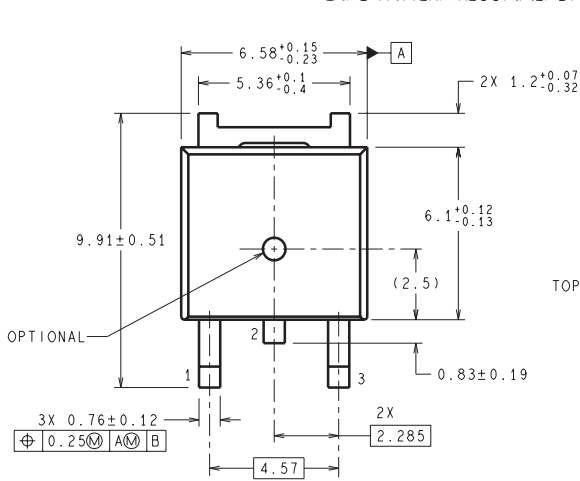

TD03B (Rev F)

DCY (R-PDSO-G4)

PLASTIC SMALL-OUTLINE

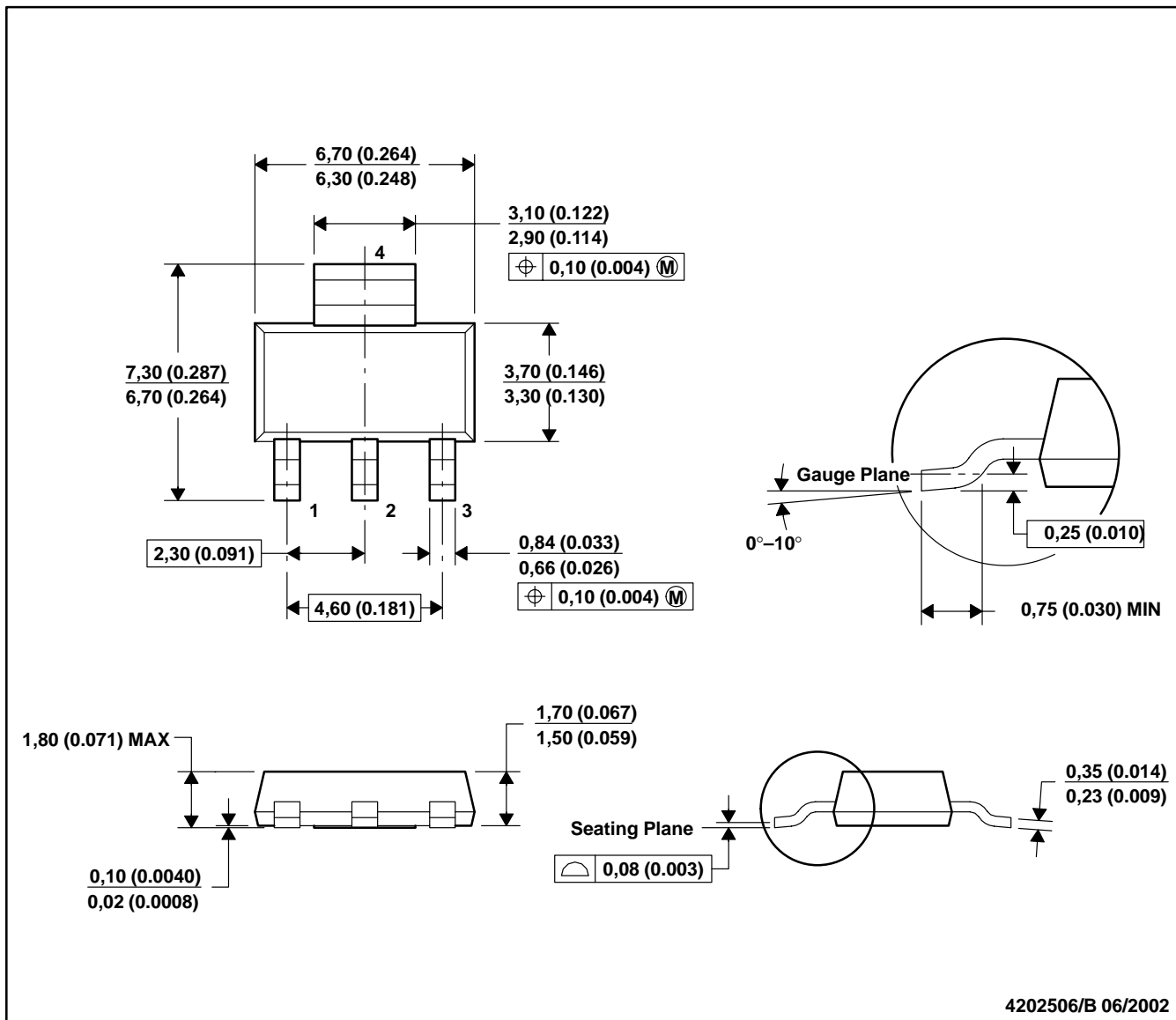

- NOTES: A. All linear dimensions are in millimeters (inches).
 B. This drawing is subject to change without notice.
 C. Body dimensions do not include mold flash or protrusion.
 D. Falls within JEDEC TO-261 Variation AA.

KTT0003B

