

*Preliminary Specifications Subject to Change without Notice*

### DESCRIPTION

The JW<sup>®</sup>5121 is a current mode monolithic buck switching regulator. Operating with an input range of 4.5V~60V, the JW5121 delivers 2A of continuous output current with an integrated high side N-Channel MOSFET. At light loads, the regulator operates in low frequency to maintain high efficiency and low output ripple. Current mode control provides tight load transient response and cycle-by-cycle current limit.

The JW5121 guarantees robustness with short-circuit protection, thermal protection, current run-away protection, and input under voltage lockout.

The JW5121 is available in 8-pin ESOP package, which provides a compact solution with minimal external components.

Company's Logo is Protected, "JW" and "JOULWATT" are Registered Trademarks of JoulWatt technology Inc.

### FEATURES

- 4.5V to 60V operating input range
- 2A output current
- High efficiency at light load
- Internal soft-start (ESOP8)
- Adjustable switching frequency
- Input under voltage lockout
- Current run-away protection
- Short circuit protection
- Thermal protection
- Available in ESOP8 package

### APPLICATIONS

- Distributed Power Systems
- Automotive Systems
- High Voltage Power Conversion
- Industrial Power Systems
- Battery Powered Systems

### TYPICAL APPLICATION

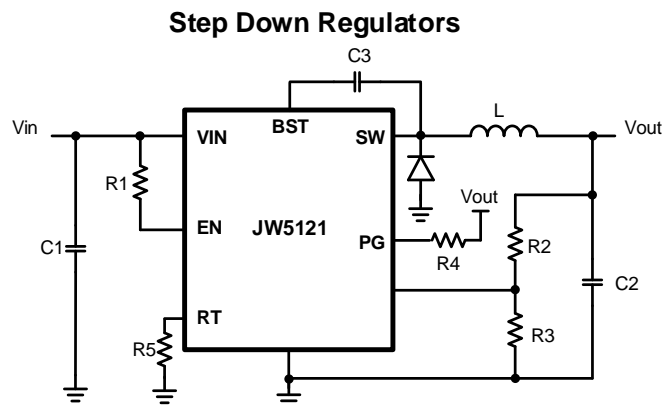

**ORDER INFORMATION**

DEVICE <sup>1)</sup>	PACKAGE	TOP MARKING <sup>2)</sup>
JW5121ESOP#TRPBF	ESOP8	JW5121 YW□□□□□

**Notes:**

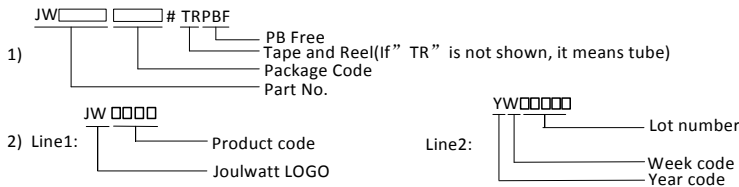

**PIN CONFIGURATION**

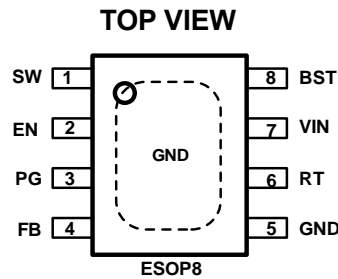

**ABSOLUTE MAXIMUM RATING<sup>1)</sup>**

VIN, EN .....	-0.3V to 66V
SW Pin .....	-0.3V(-5V for 10ns) to 66V
BST Pin .....	SW-0.3V to SW+5V
PG Pin .....	-0.3V to 22V
All other Pins .....	-0.3V to 6V
Junction Temperature <sup>2)</sup> .....	150°C
Lead Temperature .....	260°C
Storage Temperature .....	-65°C to +150°C

**RECOMMENDED OPERATING CONDITIONS<sup>3)</sup>**

Input Voltage VIN .....	4.5V to 60V
Output Voltage Vout.....	0.8V to Dmax x VIN V
Operating Junction Temperature .....	-40°C to 125°C

**THERMAL PERFORMANCE<sup>4)</sup>**

	$\theta_{JA}$	$\theta_{JC}$
ESOP8 .....	50...10°C/W	

**Note:**

- 1) Exceeding these ratings may damage the device. These stress ratings do not imply function operation of the device at any other conditions beyond those indicated under RECOMMEND OPERATION CONDITIONS.
- 2) The JW5121 includes thermal protection that is intended to protect the device in overload conditions. Continuous operation over the specified absolute maximum operating junction temperature may damage the device.
- 3) The device is not guaranteed to function outside of its operating conditions.
- 4) Measured on JESD51-7, 4-layer PCB.

## ELECTRICAL CHARACTERISTICS

<i>V<sub>IN</sub> = 12V, T<sub>A</sub> = 25°C, unless otherwise stated.</i>						
Item	Symbol	Condition	Min.	Typ.	Max.	Units
V <sub>IN</sub> Under Voltage Lockout Threshold	V <sub>IN_MIN</sub>	V <sub>IN</sub> rising	3.4	3.6	3.85	V
V <sub>IN</sub> Under Voltage Lockout Hysteresis	V <sub>IN_MIN_HYST</sub>			200		mV
Shutdown Supply Current	I <sub>SD</sub>	V <sub>EN</sub> =0V		1	4	μA
Supply Current	I <sub>Q</sub>	V <sub>EN</sub> =5V, V <sub>FB</sub> =1V		130	160	μA
Feedback Voltage	V <sub>FB</sub>	4.5V < V <sub>IN</sub> < 60V	788	800	812	mV
Power Switch Resistance	R <sub>DS(ON)T</sub>		250	280	310	mΩ
Power Switch Leakage Current	I <sub>LEAK</sub>	V <sub>IN</sub> =60V, V <sub>EN</sub> =0V, V <sub>SW</sub> =0V			1	uA
Power Switch Current Limit	I <sub>LIM</sub>	Minimum Duty Cycle	3	3.5	4	A
Switch Frequency	f <sub>SW</sub>	R <sub>RT</sub> =220k	160	200	240	kHz
Switch Frequency Range	f <sub>SW</sub>		100		2000	kHz
Minimum On Time <sup>5)</sup>	T <sub>ON_MIN</sub>		96	100	115	ns
Minimum Off Time	T <sub>OFF_MIN</sub>	V <sub>FB</sub> =0V		100		ns
Soft-start Time <sup>5)</sup>	T <sub>SS</sub>	ESOP8		0.8		ms
Soft-start Charge Current	I <sub>SS</sub>			10		uA
Power Good Lower Threshold	PG <sub>LTH</sub>	FB falling	84%	87%	90%	V <sub>REF</sub>
Power Good Upper Threshold	PG <sub>DTH</sub>	FB rising	109%	112%	115%	V <sub>REF</sub>
Power Good Sink Current	I <sub>PG</sub>	V <sub>PG</sub> =0.4V	1			mA
Power Good Delay	PG <sub>DLY</sub>	PG from low to high		240		us
EN Shut Down Threshold Voltage	V <sub>EN_H</sub>	V <sub>EN</sub> rising		1.4	1.52	V
	V <sub>EN_L</sub>	V <sub>EN</sub> falling	1	1.2		
EN Shut Down Hysteresis	V <sub>EN_HYST</sub>			200		mV
Thermal Shutdown <sup>5)</sup>	T <sub>TSD</sub>			150		°C
Thermal Shutdown Hysteresis <sup>5)</sup>	T <sub>TSD_HYST</sub>			15		°C

**Note:**

5) Guaranteed by design.

**PIN DESCRIPTION**

Name		Description
<b>ESOP8</b>		
1	SW	SW is the switching node that supplies power to the output. Connect the output LC filter from SW to the output load.
2	EN	Drive EN pin high to turn on the regulator and low to turn off the regulator.
3	PG	Open drain output for power-good flag. Use a 100kΩ pull-up resistor to logic rail or other DC voltage no higher than 20V.
4	FB	Output feedback pin. FB senses the output voltage and is regulated by the control loop to 800mV. Connect a resistive divider at FB.
5/EP	GND	Ground.
6	RT	Switching Frequency Program Input. Connect a resistor from this pin to ground to set the switching frequency.
7	VIN	Input voltage pin. VIN supplies power to the IC. Connect a 4.5V to 60V supply to VIN and bypass VIN to GND with a suitably large capacitor to eliminate noise on the input to the IC.
8	BST	Bootstrap pin for top switch.

**BLOCK DIAGRAM**

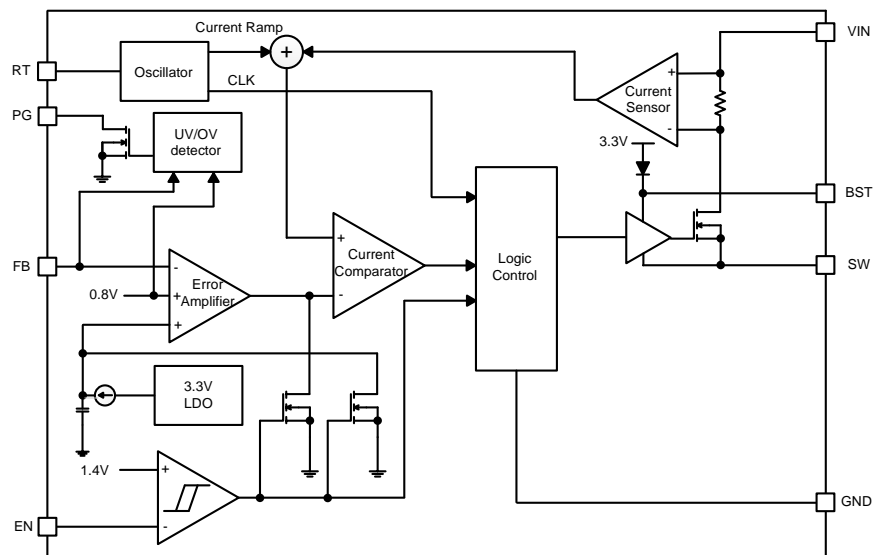

# TYPICAL PERFORMANCE CHARACTERISTICS

$V_{in} = 12V$ ,  $V_{out} = 5V$ ,  $F_s = 500KHz$ ,  $L = 10\mu H$ ,  $C_{out} = 44\mu F$ ,  $T_A = +25^\circ C$ , unless otherwise noted

### Steady State Test

$I_{out} = 2A$

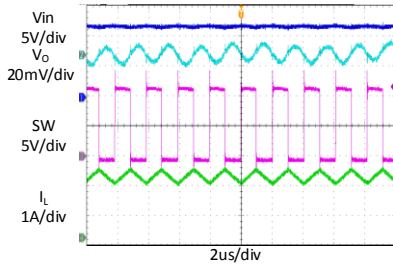

### Startup through Enable

$I_{out} = 2A$  (Resistive load)

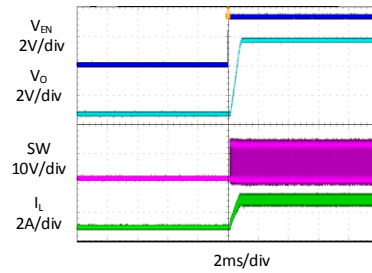

### Shutdown through Enable

$I_{out} = 2A$  (Resistive load)

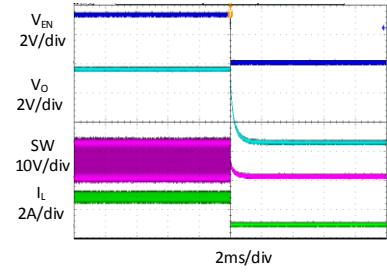

### Heavy Load Operation

2A LOAD

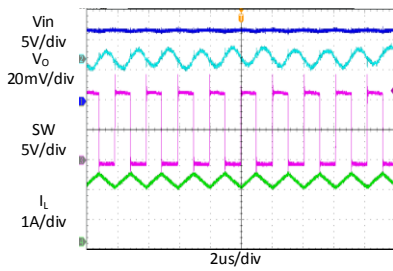

### Medium Load Operation

1.1A LOAD

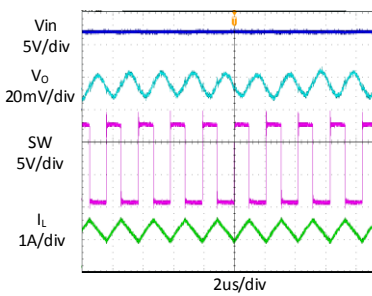

### Light Load Operation

0 A LOAD

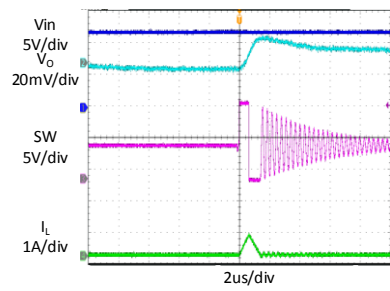

### Short Circuit Protection

$I_{out} = 2A$  - Short

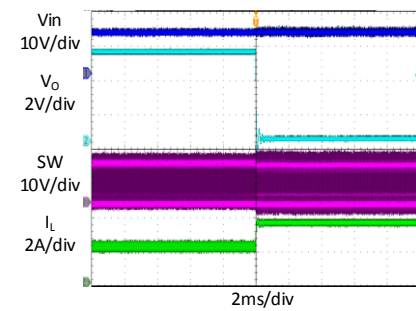

### Short Circuit Protection

$I_{out} = \text{Short} - 2A$

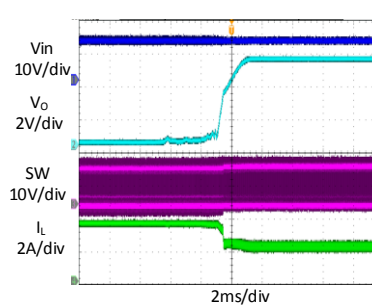

### Load Transient

0.2A LOAD  $\rightarrow$  2A LOAD  $\rightarrow$  0.2A LOAD

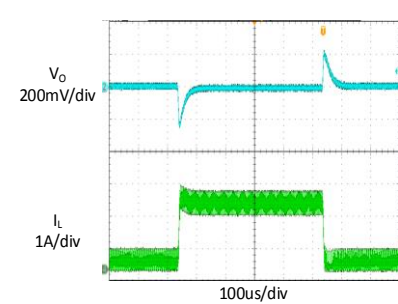

**TYPICAL PERFORMANCE CHARACTERISTICS (continued)**

Vout = 5V, L = 10μH, Cout = 44μF, TA = +25°C, unless otherwise noted

**Quiescent Current Vs. Input Voltage**

VIN=5V ~ 60V, VEN=3V, VFB=1V

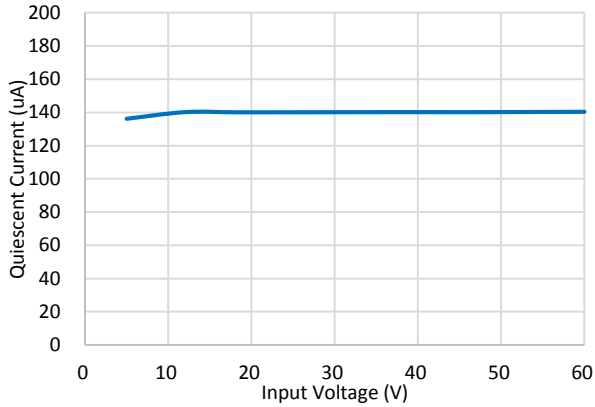

**Shutdown Current Vs. Input Voltage**

VIN=5V ~ 60V, VEN=0V, VFB=0.3V

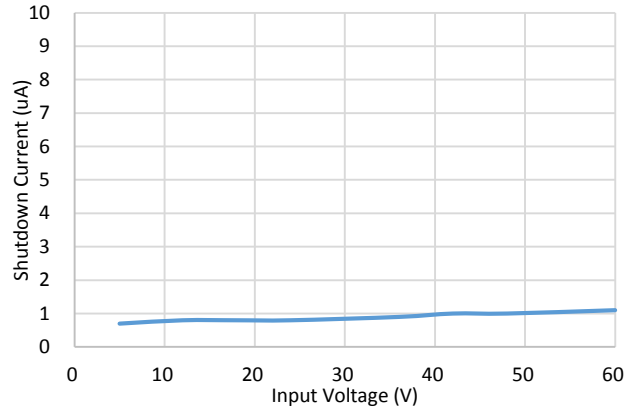

**Efficiency @ 300KHz**

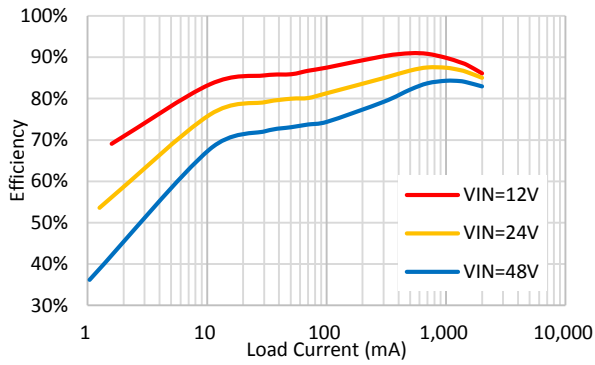

**Efficiency @ 500KHz**

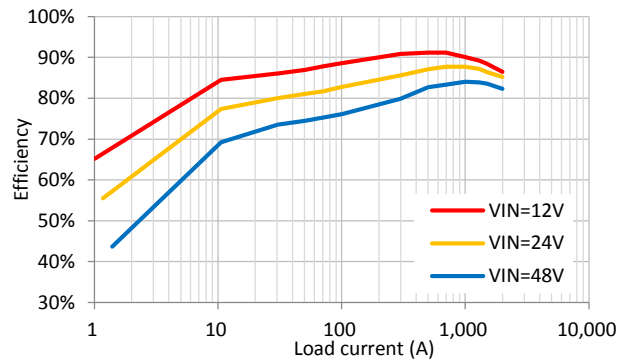

**Efficiency @ 1MHz**

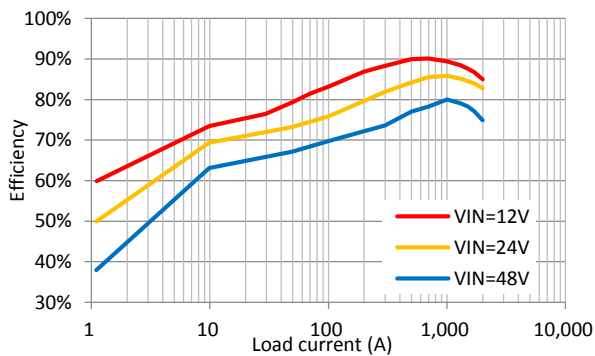

**Load Regulation @ 300KHz**

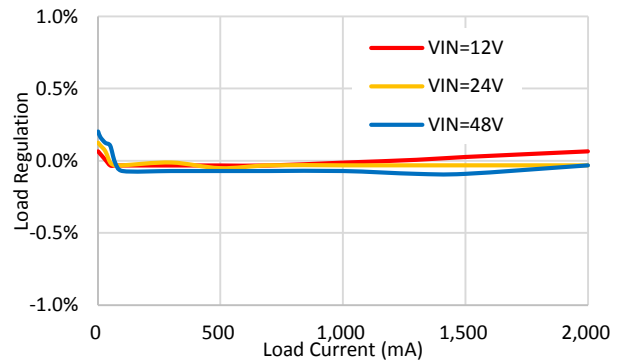

Load Regulation @ 500KHz

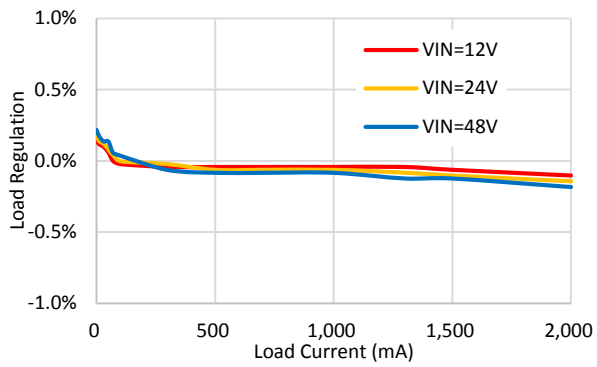

Load Regulation @ 1MHz

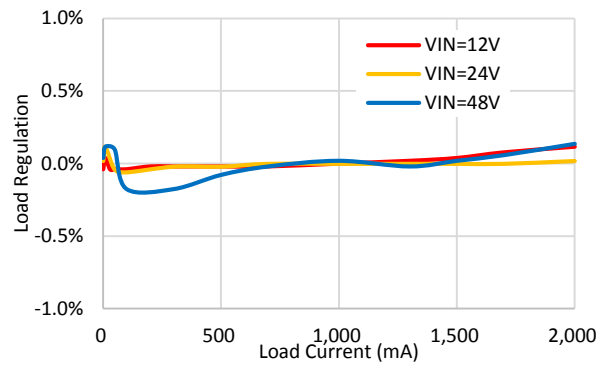



## FUNCTIONAL DESCRIPTION

The JW5121 is an asynchronous, current-mode, step-down regulator. It regulates input voltages from 4.5V to 60V down to an output voltage as low as 0.8V, and is capable of supplying up to 2A of load current.

### Current-Mode Control

The JW5121 utilizes current-mode control to regulate the output voltage. The output voltage is measured at the FB pin through a resistive voltage divider and the error is amplified by the internal transconductance error amplifier. The voltage feedback loop is compensated by an internal RC network.

Output of the error amplifier  $V_{COMP}$  is compared with the switch current measured internally to control the output current.

### PFM Mode

The JW5121 operates in PFM mode at light load. In PFM mode, switch frequency decreases when load current drops to boost power efficiency at light load by reducing switch-loss, while switch frequency increases when load current rises, minimizing output voltage ripples.

### Shut-Down Mode

The JW5121 shuts down when voltage at EN pin is below 1V. The entire regulator is off and the supply current consumed by the JW5121 drops below 1 $\mu$ A.

### Power Switch

N-Channel MOSFET switches are integrated on the JW5121 to down convert the input voltage to the regulated output voltage. Since the top MOSFET needs a gate voltage greater than the input voltage, a boost capacitor connected between BST and SW pins is required to drive

the gate of the top switch. The boost capacitor is charged by the internal 3.3V rail when SW is low.

### Vin Under-Voltage Protection

A resistive divider can be connected between Vin and ground, with the central tap connected to EN, so that when Vin drops to the pre-set value, EN drops below 1.2V to trigger input under voltage lockout protection.

### Soft-start

Soft-start is designed in JW5121 to prevent the converter output voltage from overshooting during startup and short-circuit recovery. When the chip starts, the internal circuit generates a soft-start voltage (SS) ramping up from 0V to 1.2V. When it is less than the VREF, SS overrides VREF and the error amplifier uses SS as the reference. When SS exceeds VREF, VREF regains control.

### Switching Frequency

The switching frequency of JW5121 can be programmed by the resistor  $R_T$  from the RT pin and GND pin over a wide range from 100 kHz to 2000 kHz. The RT pin voltage is typically 1.2V and must have a resistor to ground to set the switching frequency. The  $R_T$  resistance can be calculated by the following equation for a given switching frequency  $f_{SW}$ .

$$R_T(\Omega) = \frac{1}{f_{SW}(Hz)} - 175 * 10^{-9} \\ 2.31 * 10^{-11}$$

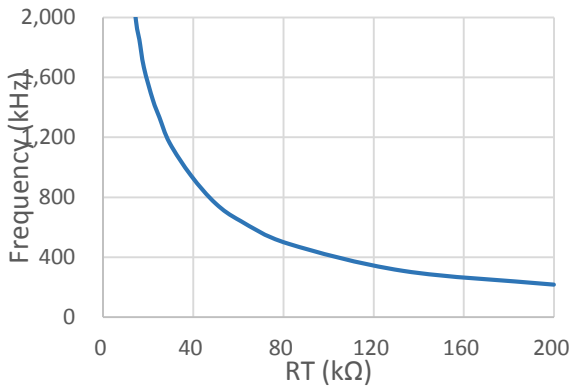

To reduce the solution size one would typically set the switching frequency as high as possible, but tradeoffs of the conversion efficiency, maximum input voltage and minimum controllable on time should be considered. The minimum controllable on time is typically 120 ns which limit the maximum operating frequency in applications with high input to output step down ratios.

**Over Current / Output Short Protection**

To protect the converter in overload conditions at higher switching frequencies and input voltages, the JW5121 implements a frequency fold-back. The oscillator frequency is divided by  $2^X (X=0, 1, 2...7)$  if the power FET current rises above the current limit by 0.5A in a minimum detection time (typ. 60ns). The fold-back frequency depends on the number of consecutive triggers. Once the power FET is turned off by the current limit instead of minimum on time, the frequency exist fold-back state.

During short-circuit events, the inductor current may exceed the peak current limit because of the high input voltage and the minimum controllable on time. When the output voltage is forced low by the shorted load, the inductor

current decreases slowly during the switch off time. The frequency fold-back effectively increases the off time by increasing the period of the switching cycle providing more time for the inductor current to ramp down. With a maximum frequency fold-back ratio of 128, there is a maximum frequency at which the inductor current can be controlled by frequency fold-back protection.

**Power Good**

The JW5121 has power-good (PG) output. The PG pin is the open drain of a MOSFET. Connect to a voltage source (such as Vout) through a resistor. When the output voltage becomes within +/-12% of the target value, internal comparators detect power good state and the power good signal becomes high. If the feedback voltage goes under or higher 12%of the target value, the power good signal becomes low.

**RT Short Protection**

If the RT pin is detected to be short to ground, JW5121 is not allowed to switch to prevent abnormal operation state. The regulator can be reactivated again when the short condition at the RT pin is removed.

**Thermal Protection**

When the temperature of the JW5121 rises above 150°C, it is forced into thermal shut-down.

Only when core temperature drops below 135°C can the regulator becomes active again.

## APPLICATION INFORMATION

### Output Voltage Set

The output voltage is determined by the resistor divider connected at the FB pin, and the voltage ratio is:

$$V_{FB} = V_{OUT} * \frac{R_3}{R_2 + R_3}$$

Where VFB is the feedback voltage and VOUT is the output voltage.

Choose R2 around 20kΩ, and then R3 can be calculated by:

$$R_3 = \frac{R_2}{\frac{V_{OUT}}{0.8} - 1}$$

Too large resistance and the following table lists the recommended values.

Vout(V)	R2(kΩ)	R3(kΩ)
3.3	20	6.4
5	20	3.8
12	20	1.4

### Input Capacitor

The input capacitor is used to supply the AC input current to the step-down converter and maintaining the DC input voltage. The ripple current through the input capacitor can be calculated by:

$$I_{C1} = I_{LOAD} * \sqrt{\frac{V_{OUT}}{V_{IN}} * \left(1 - \frac{V_{OUT}}{V_{IN}}\right)}$$

Where ILOAD is the load current, VOUT is the output voltage, VIN is the input voltage.

Thus the input capacitor can be calculated by the following equation when the input ripple voltage is determined.

$$C_1 = \frac{I_{LOAD}}{f_s * \Delta V_{IN}} * \frac{V_{OUT}}{V_{IN}} * \left(1 - \frac{V_{OUT}}{V_{IN}}\right)$$

Where C1 is the input capacitance value, fs is the switching frequency, ΔVIN is the input ripple voltage.

The input capacitor can be electrolytic, tantalum or ceramic. To minimizing the potential noise, a small X5R or X7R ceramic capacitor, i.e. 0.1uF, should be placed as close to the IC as possible when using electrolytic capacitors.

A 4.7~10uF ceramic capacitor is recommended in typical application.

### Output Capacitor

The output capacitor is required to maintain the DC output voltage, and the capacitance value determines the output ripple voltage. The output voltage ripple can be calculated by:

$$\Delta V_{OUT} = \frac{V_{OUT}}{f_s * L} * \left(1 - \frac{V_{OUT}}{V_{IN}}\right) * \left(R_{ESR} + \frac{1}{8 * f_s * C_2}\right)$$

Where C2 is the output capacitance value and RESR is the equivalent series resistance value of the output capacitor.

The output capacitor can be low ESR electrolytic, tantalum or ceramic, which lower ESR capacitors get lower output ripple voltage.

A 22~66uF ceramic capacitor is recommended in typical application.

### Inductor

The inductor is used to supply constant current to the output load, and the value determines the ripple current which affect the efficiency and the output voltage ripple. The ripple current is typically allowed to be 40% of the maximum

switch current limit, thus the inductance value can be calculated by:

$$L = \frac{V_{OUT}}{f_s * \Delta I_L} * (1 - \frac{V_{OUT}}{V_{IN}})$$

Where VIN is the input voltage, VOUT is the output voltage, fs is the switching frequency, and Δ IL is the peak-to-peak inductor ripple current.

**PCB Layout Note**

For minimum noise problem and best operating performance, the PCB is preferred to following the guidelines as reference.

1. Place the input decoupling capacitor as close to JW5121 (VIN pin and GND) as possible to eliminate noise at the input pin. The loop area formed by input capacitor and GND must be minimized.
2. Put the feedback trace as far away from the inductor and noisy power traces as possible. The ground plane on the PCB should be as large as possible for better heat dissipation.

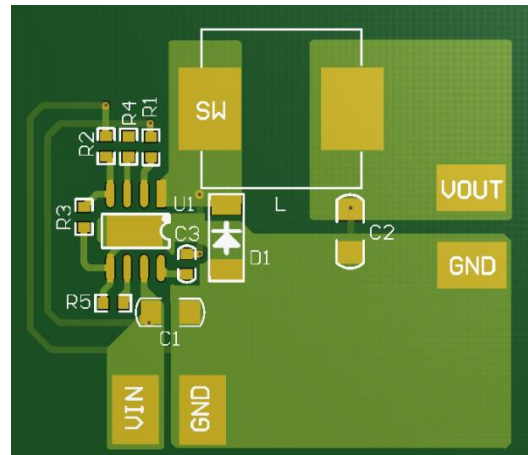

Figure1. PCB Layout Recommendation

REFERENCE DESIGN

Reference 1:

Vin: 7V~60V

Vout: 5V

Iout: 0~2A

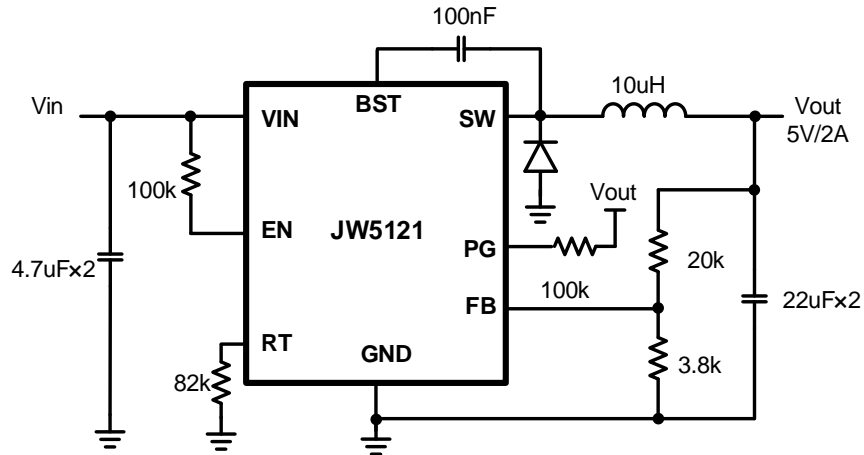

Reference 2:

Vin: 5V~60V

Vout: 3.3V

Iout: 0~2A

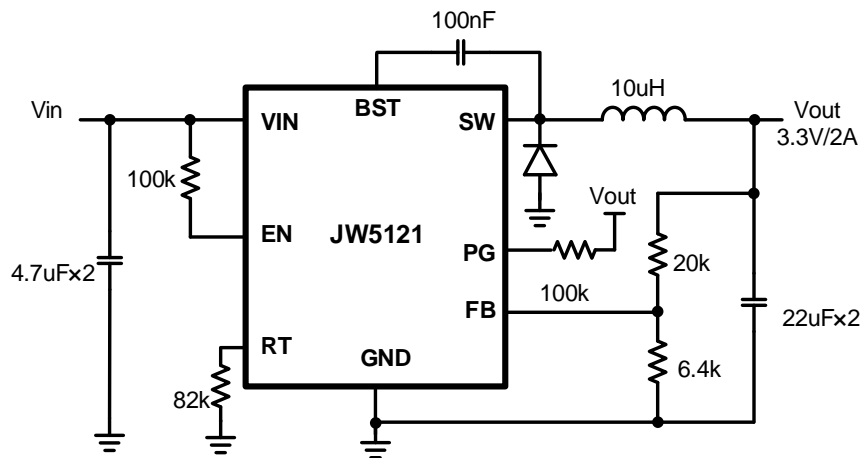

**Reference 3:**

Vin: 14V~60V

Vout: 12V

Iout: 0~2A

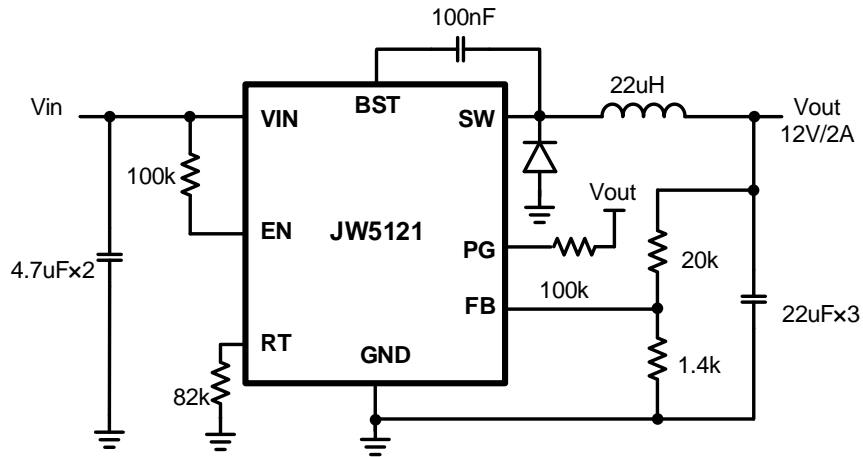

**Reference 4:**

Vin: 8V~25V

Vout: 5V

Iout: 0~2A

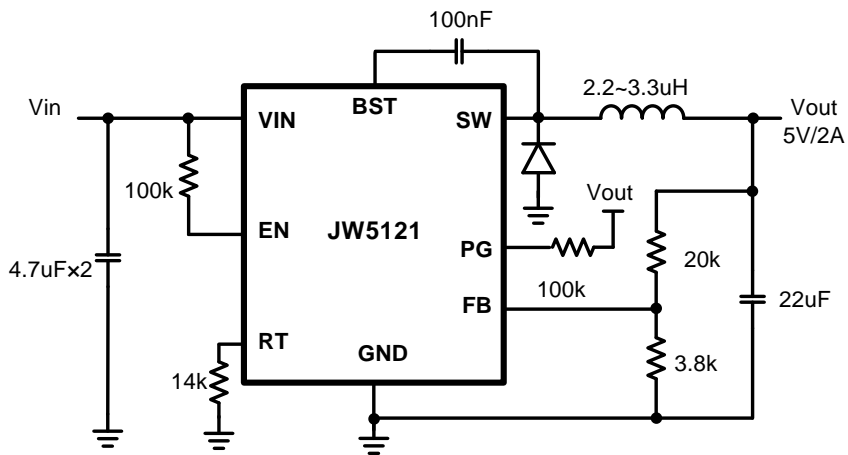

TAPE AND REEL INFORMATION

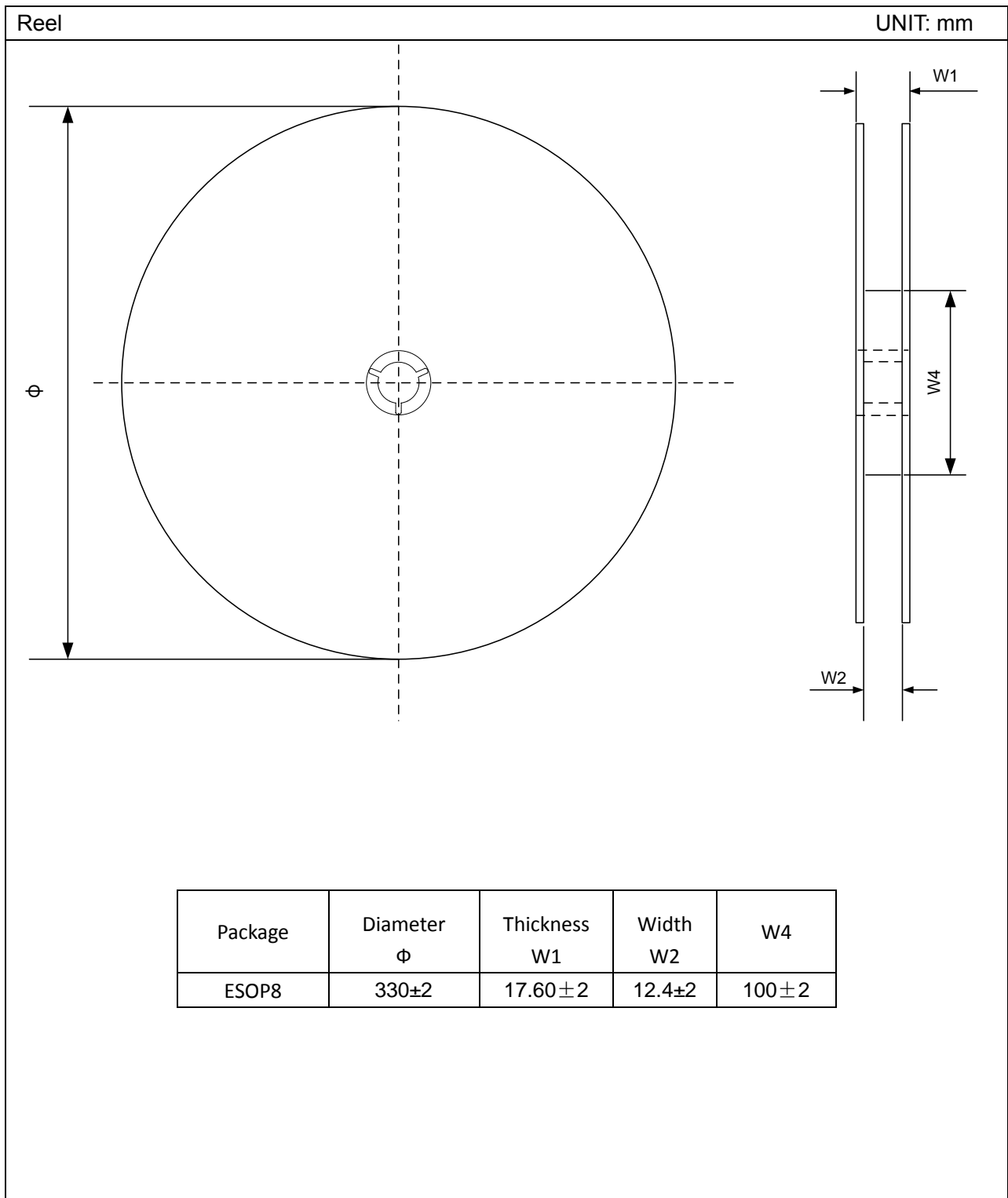

Carrier Tape

UNIT: mm

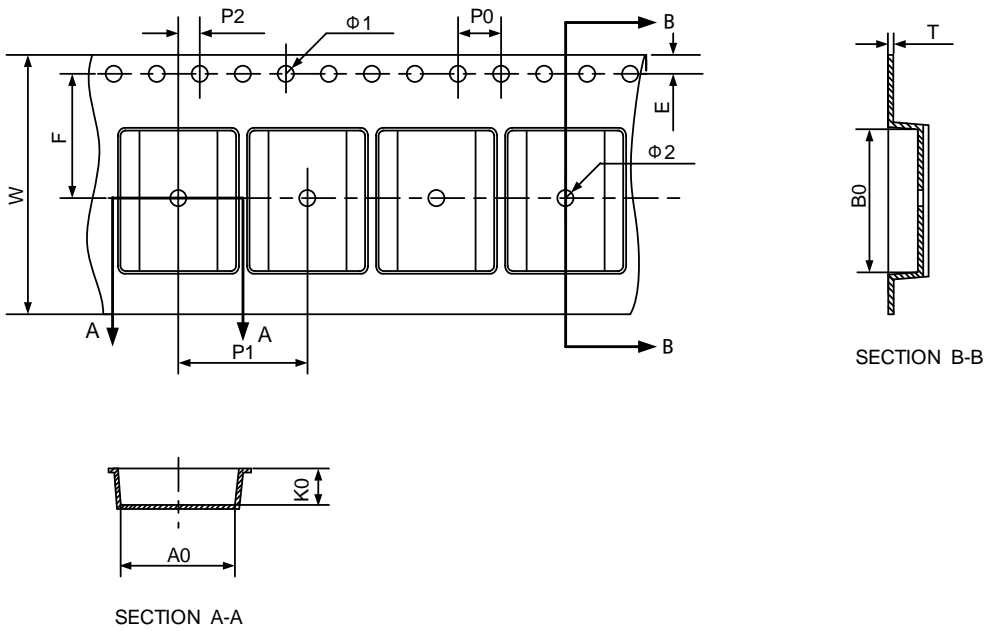

Note :

- 1) The carrier type is black, and colorless transparent.
- 2) Carrier camber is within 1mm in 100mm.
- 3) 10 pocket hole pitch cumulative tolerance:±0.20.
- 4) All dimensions are in mm.

Package	Tape dimensions (mm)											
	P0	P2	P1	A0	B0	W	T	K0	Φ1	Φ2	E	F
ESOP8	4.0±0.1	2.0±0.1	8.0±0.1	6.40±0.3	5.35±0.3	12.0±0.3	0.25±0.2	2.0±0.2	1.50min	1.50min	1.75±0.1	5.50±0.1



PACKAGE OUTLINE

ESOP8
Unit: mm

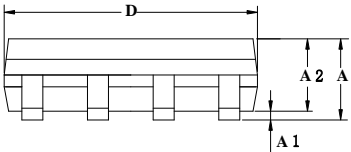
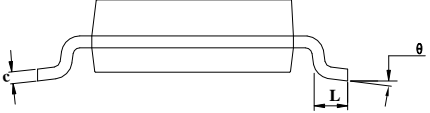

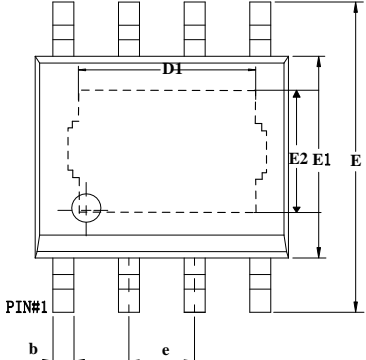
Symbol	MILLIMETER		
	MIN	NOM	MAX
A	1.30	—	1.70
A1	0.00	—	0.10
A2	1.35	—	1.55
b	0.33	—	0.51
c	0.17	—	0.25
D	4.70	—	5.10
E	5.80	6.00	6.20
E1	3.80	3.90	4.00
D1	3.05	—	3.25
E2	2.16	—	2.36
e	1.27BSC		
L	0.40	—	1.27
θ	0°	—	8°

QUADRANT ASSIGNMENTS FOR PIN 1 ORIENTATION IN TAPAE

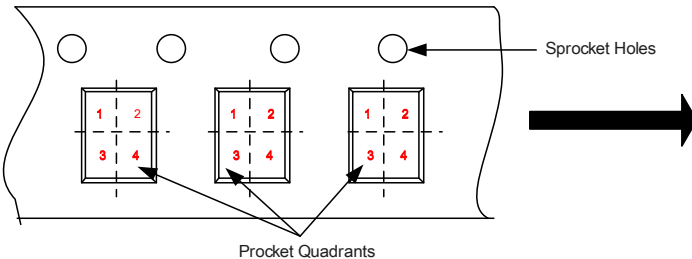

Sprocket Holes

Sprocket Quadrants

Package Type	Pin1 Quadrant
ESOP8	1

JW5121 Rev.0.25

JoulWatt® Proprietary Information. Patent Protected.

17

2022/05/06

Unauthorized Photocopy and Duplication Prohibited.

**IMPORTANT NOTICE**

- Joulwatt Technology Inc. reserves the right to make modifications, enhancements, improvements, corrections or other changes without further notice to this document and any product described herein.
- Any unauthorized redistribution or copy of this document for any purpose is strictly forbidden.
- Joulwatt Technology Inc. does not warrant or accept any liability whatsoever in respect of any products purchased through unauthorized sales channel.

*Copyright © 2018 JW5121 Incorporated.*

*All rights are reserved by Joulwatt Technology Inc.*