

Datasheet

FS361

One Cell Lithium-ion/Polymer Battery Protection IC

Fortune Semiconductor Corporation

富晶電子股份有限公司

28F., No.27, Sec. 2, Zhongzheng E. Rd.,
Danshui Town, Taipei County 251, Taiwan

Tel. : 886-2-28094742

Fax : 886-2-28094874

www.ic-fortune.com

This manual contains new product information. **Fortune Semiconductor Corporation** reserves the rights to modify the product specification without further notice. No liability is assumed by **Fortune Semiconductor Corporation** as a result of the use of this product. No rights under any patent accompany the sale of the product.

1. General Description

The FS361 battery protection IC is designed to protect lithium-ion/polymer battery from damage or degrading the lifetime due to overcharge, overdischarge for one-cell lithium-ion/polymer battery powered systems, such as cellular phones.

The ultra-small package and less required external components make it ideal to integrate the FS361 into the limited space of battery pack. The accurate $\pm 50\text{mV}$ overcharging detection voltage ensures safe and full utilization charging. The very low standby current drains little current from the cell while in storage.

2. Features

Reduction in Board Size due to Miniature Package SOT-23-6.

Supply Current at $3\ \mu\text{A}$ ($V_{\text{CC}}=3.65\text{V}$).

Power-Down Current at $0.1\ \mu\text{A}$ ($V_{\text{CC}}=1.9\text{V}$).

Precision Overcharge Protection Voltage $\text{VOCP} \pm 50\text{mV}$

Load Detection Function during Overcharge Mode.

Delay times are generated by internal circuits. No external capacitors required.

3. Ordering Information

FS361x-P (x: serial code)

PACKAGE TYPE

SOT-23-6 (Pb-free)

TEMPERATURE RANGE

$-40^{\circ}\text{C}\sim+85^{\circ}\text{C}$

4. Applications

Protection IC for One-Cell Lithium-Ion / Lithium-Polymer Battery Pack

5. Product Name List

Model	Package	Overcharge Protection voltage [VOCP] (V)	Overcharge release voltage [VOCR] (V)	Overdischarge Protection voltage [VODP] (V)	Overdischarge release voltage [VODR] (V)
	SOT-23-6				
FS361A	FS361A	3.750±0.050	3.500±0.050	2.000±0.050	2.650±0.050
FS361B*	FS361B	4.050±0.050	3.500±0.050	2.050±0.050	2.300±0.050
FS361C	FS361C	4.050±0.050	3.500±0.050	2.050±0.050	2.300±0.050

Note: * FS361B has Overcurrent Protection function. Below is the Specification:

PARAMETER	TEST CONDITIONS	SYMBOL	Min	Typ	Max	UNIT
Overcurrent Protection Voltage		VOIP(VOI1)	120	150	180	mV
Overcurrent Delay Time(1)	VCC=3.6V	TOI1		10	20	ms

6. Pin Configuration and Package Marking Information

Pin No.	Symbol	Description
1	OD	MOSFET gate connection pin for discharge control
2	CS	Input pin for current sense, charger detect
3	OC	MOSFET gate connection pin for charge control
4	TD	Test pin for reduce delay time
5	VCC	Power supply, through a resistor (R1)
6	GND	Ground pin

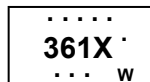
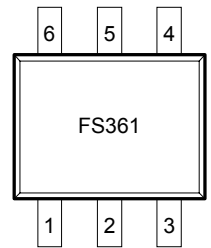

Top Point : Lot No.
 Bottom Point : Year
 w : week, A~Z & A ~ Z
 A dot after marking : Pb Free

7. Functional Block Diagram

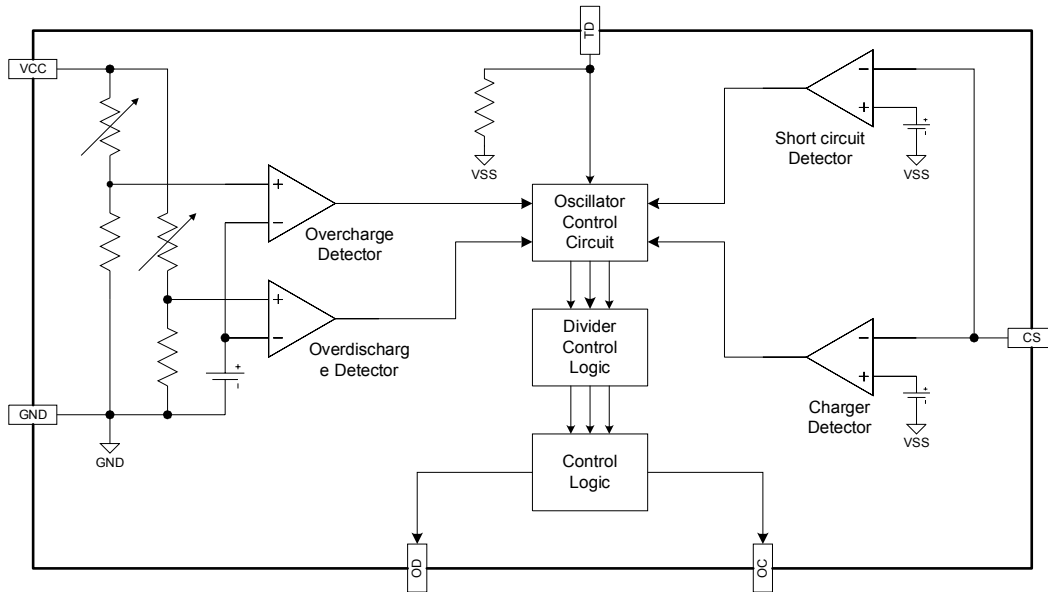

8. Typical Application Circuit

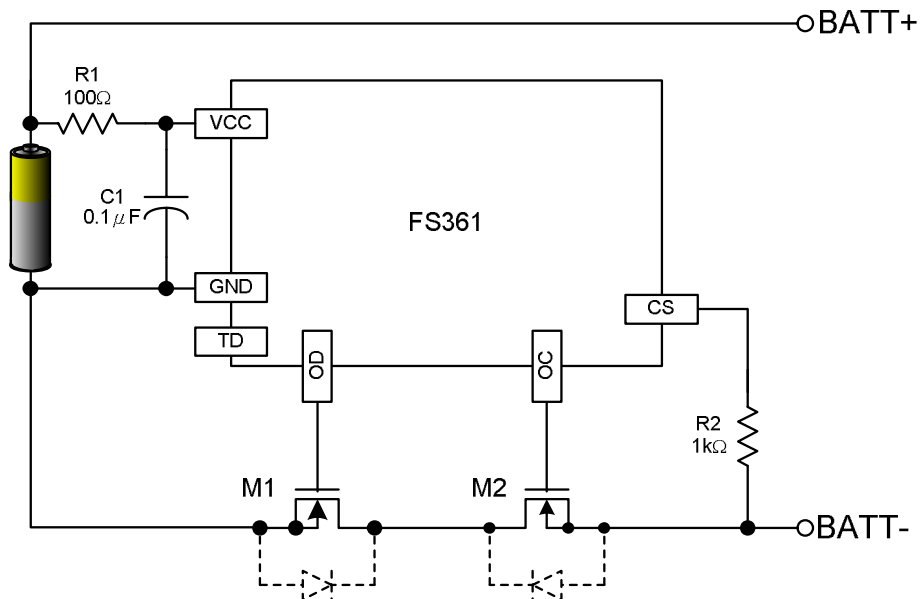

9. Absolute Maximum Ratings

(GND=0V, Ta=25°C unless otherwise specified)

Item	Symbol	Rating	Unit
Input voltage between VCC and GND *	VCC	GND-0.3 to GND+10	V
OC output pin voltage	VOC	VCC -24 to VCC +0.3	V
OD output pin voltage	VOD	GND-0.3 to VCC +0.3	V
CS input pin voltage	VCS	VCC -24 to VCC +0.3	V
Operating Temperature Range	TOP	-40 to +85	°C
Storage Temperature Range	TST	-40 to +125	°C

Note: FS361 contains a circuit that will protect it from static discharge; but please take special care that no excessive static electricity or voltage which exceeds the limit of the protection circuit will be applied to it.

10. Electrical Characteristics

(Ta=25°C unless otherwise specified)

PARAMETER	TEST CONDITIONS	SYMBOL	Min	Typ	Max	UNIT
Supply Current	VCC=3.65V	ICC		3.0	6.0	μA
Power-Down Current	VCC=1.9V	IPD			0.1	μA
Overcharge Protection Voltage	FS361	VOCP	VOCP-0.05	VOCP	VOCP+0.05	V
Overcharge Release Voltage		VOCR	VOCR-0.05	VOCR	VOCR+0.05	V
Overdischarge Protection Voltage		VODP	VODP-0.05	VODP	VODP+0.05	V
Overdischarge Release Voltage		VODR	VODR-0.05	VODR	VODR+0.05	V
Short Current Protection Voltage	VCC=3.6V	VSIP (VOI2)	1.00	1.35	1.70	V
Overcharge Delay Time		TOC		80	200	ms
Overdischarge Delay Time	VCC=3.6V to 2.0V	TOD		40	100	ms
Short current Delay Time	VCC=3.6V	TOI2		5	50	μs
Charger Detection Threshold Voltage		VCHA	-1.2	-0.7	-0.2	V
OD Pin Output "H" Voltage		VDH	VCC-0.1	VCC-0.02		V
OD Pin Output "L" Voltage		VDL		0.1	0.5	V
OC Pin Output "H" Voltage		VCH	VCC-0.1	VCC-0.02		V
OC Pin Output "L" Voltage		VCL		0.1	0.5	V

11. Description of Operation

11.1 Overcharge Protection

When the voltage of the battery cell exceeds the overcharge protection voltage (VOCP) beyond the overcharge delay time (TOC) period, charging is inhibited by turning off of the charge control MOSFET. The overcharge condition is released in two cases:

The voltage of the battery cell becomes lower than the overcharge release voltage (VOCR) through self-discharge.

The voltage of the battery cell falls below the overcharge protection voltage (VOCP) and a load is connected.

When the battery voltage is above VOCP, the overcharge condition will not release even a load is connected to the pack.

11.2 Overdischarge Protection

When the voltage of the battery cell goes below the overdischarge protection voltage (VODP) beyond the overdischarge delay time (TOD) period, discharging is inhibited by turning off the discharge control MOSFET. The default of overdischarge delay time is 10ms. Inhibition of discharging is immediately released when the voltage of the battery cell becomes higher than overdischarge release voltage (VODR) through charging.

11.3 Short current Protection

In normal mode, the FS361 continuously monitors the discharge current by sensing the voltage of CS pin. If the voltage of CS pin exceeds the short current protection voltage (VOI2) beyond the short current delay time (TOI2) period, the short current protection circuit operates and discharging is inhibited by turning off the discharge control MOSFET. The short current condition returns to the normal mode when the load is released or the impedance between BATT+ and BATT- is larger than 500k Ω . The FS361 provides short current detection levels (1.35V) with delay time (TOI2).

11.4 Charge Detection after Overdischarge

When overdischarge occurs, the discharge control MOSFET turns off and discharging is inhibited. However, charging is still permitted through the parasitic diode of MOSFET. Once the charger is connected to the battery pack, the FS361 immediately turns on all the timing generation and detection circuitry. Charging progress is sensed if the voltage between CS and GND is below charge detection threshold voltage (VCH).

11.5 Power-Down after Overdischarge

When overdischarge occurs, the FS361 will enter into power-down mode, turning off all the timing generation and detection circuitry to reduce the quiescent current to 0.1 μ A (VCC=2.0V). At the same time, the CS pin is pull-up to VCC through an internal resistor.

12. Design Guide

12.1 Suppressing the Ripple and Disturbance from Charger

To suppress the ripple and disturbance from charger, connecting R1 and C1 to VCC is recommended.

12.2 Protection the CS pin

R2 is used for latch-up protection when charger is connected under overdischarge condition and overstress protection at reverse connecting of a charger.

13. Timing Diagram

13.1 Overcharge Condition → Load Discharging → Normal Condition

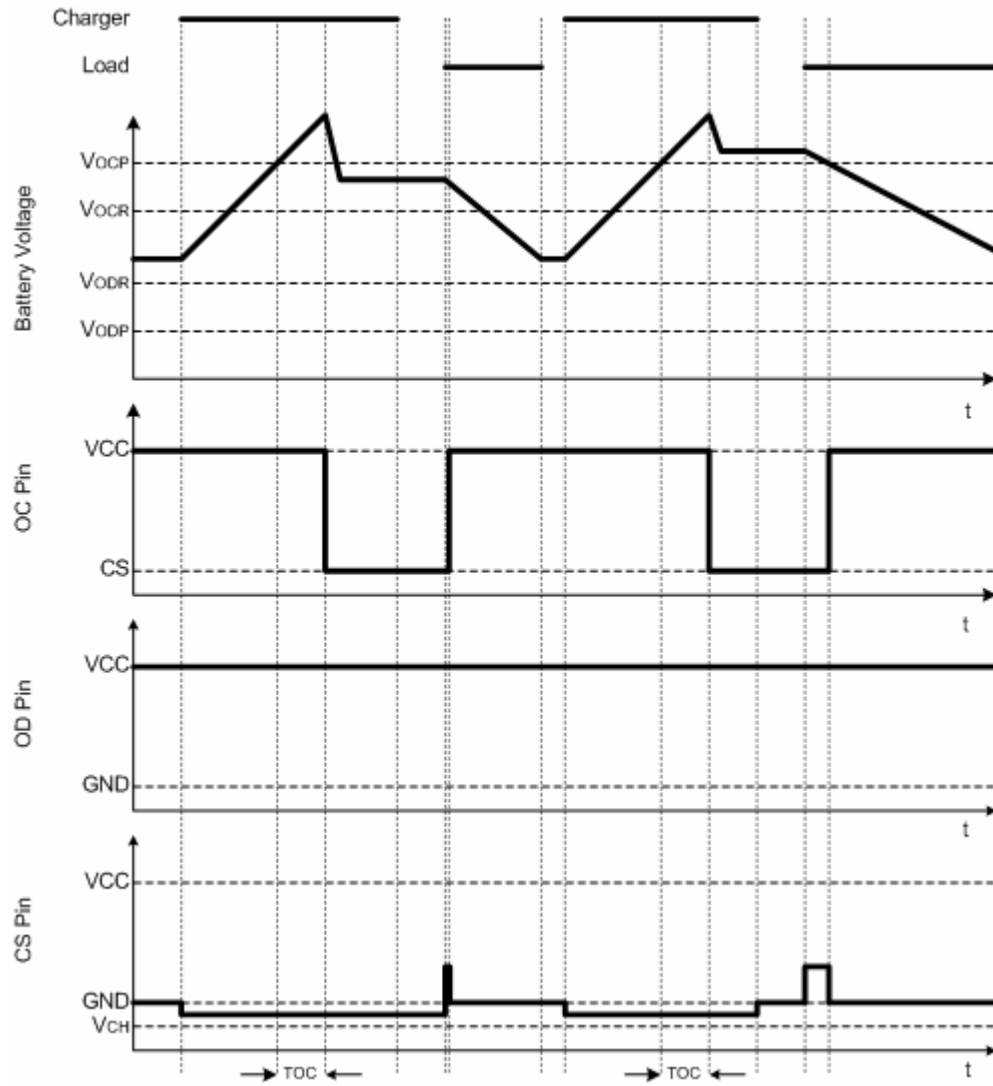

13.2 Overdischarge Condition → Charging by a Charger → Normal Condition

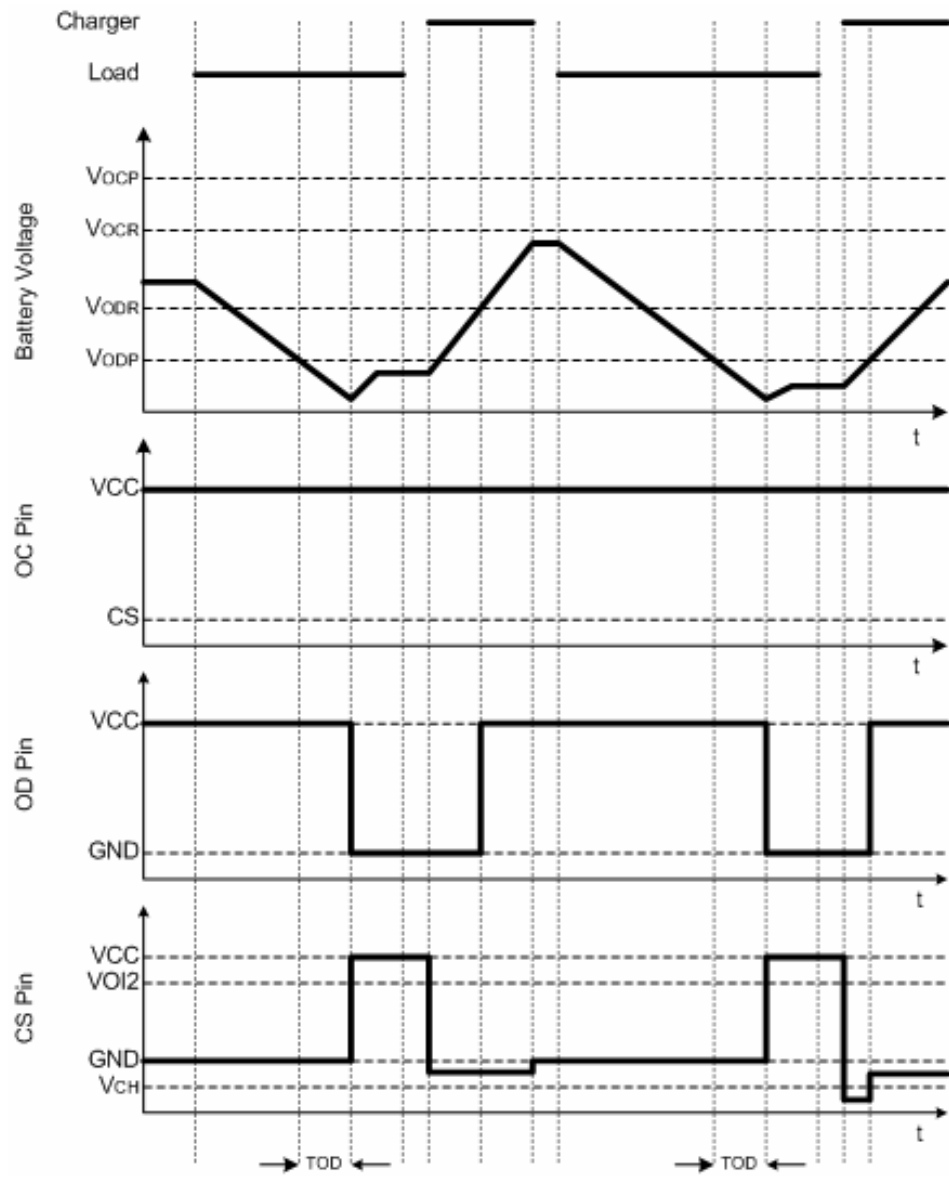

13.3 Over Current Condition → Normal Condition

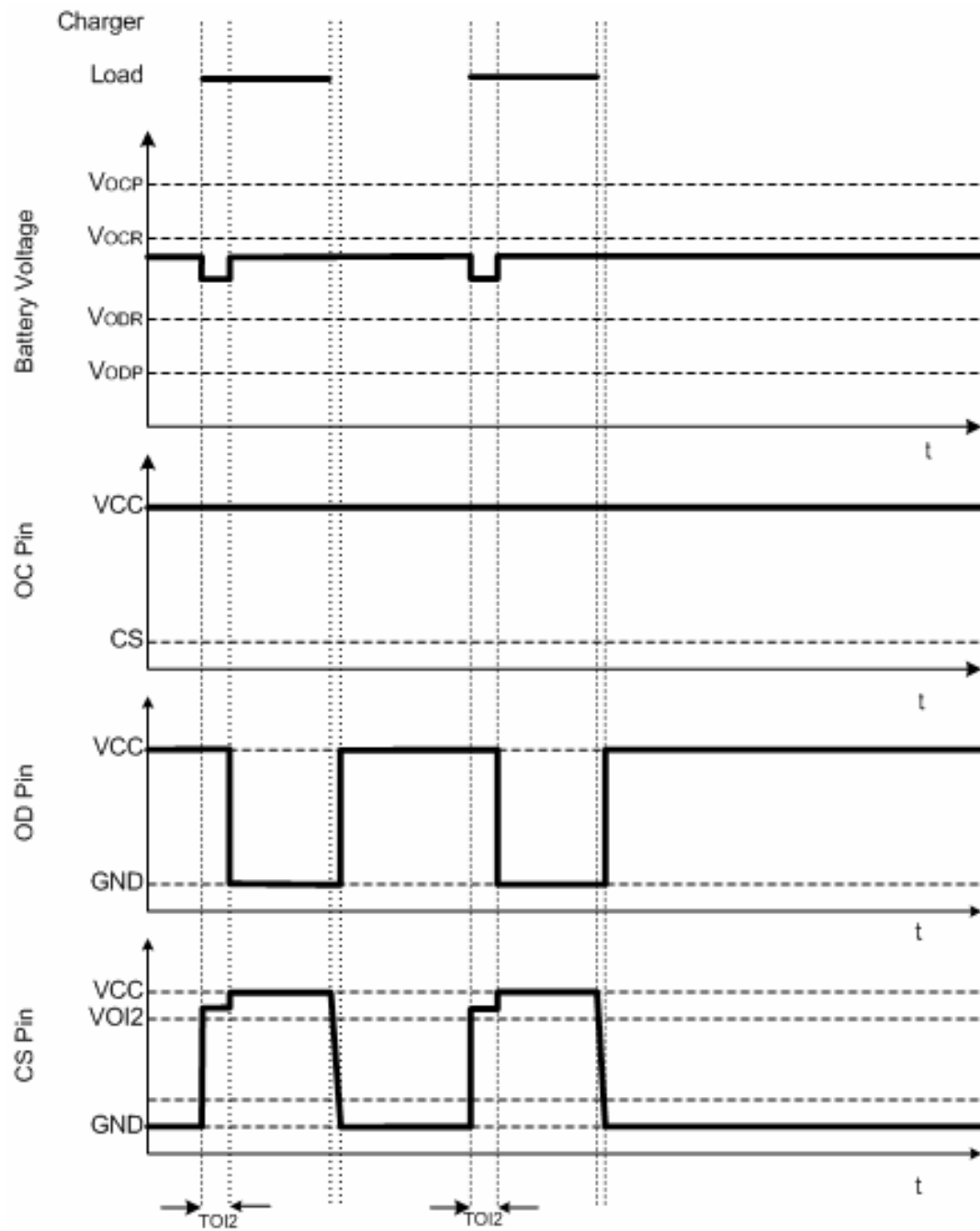

14. Package Outline

Dimension (Package A)

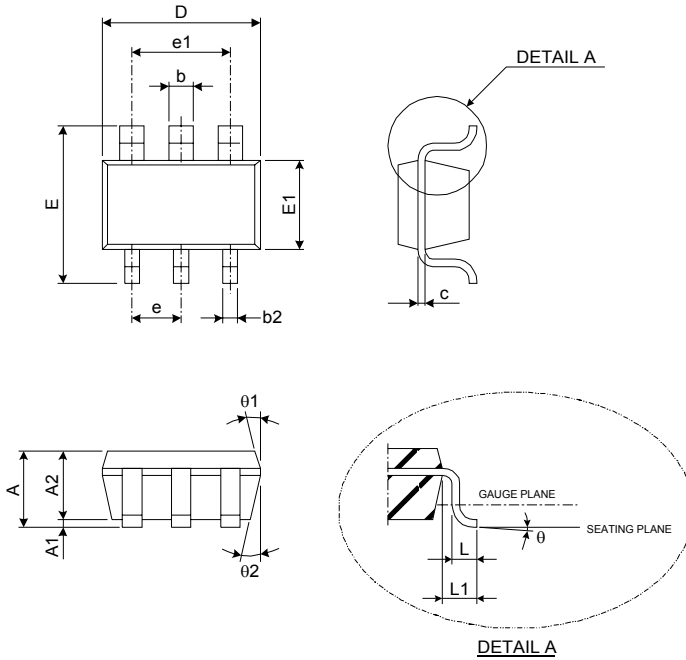

Unit : mm

SYMBOL	MIN.	TYP.	MAX.
A	1.05	-	1.35
A1	0.05	-	0.15
A2	1.00	1.10	1.20
b	0.40	-	0.55
b2	0.25	-	0.40
c	0.08	-	0.20
D	2.70	2.90	3.00
E	2.60	2.80	3.00
E1	1.50	1.60	1.70
L	0.35	0.45	0.55
L1	0.60 REF.		
e	0.95 BSC.		
e1	1.90 BSC.		
θ	0°	5°	10°
θ_1	3°	5°	7°
θ_2	6°	8°	10°

Dimension (Package B)

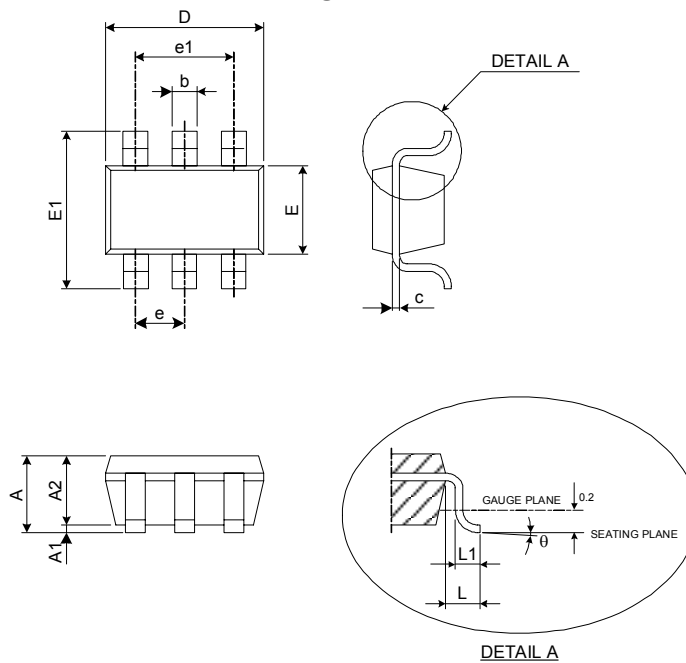

Unit : mm

SYMBOL	MIN.	TYP.	MAX.
A	1.050	-	1.250
A1	0.000	-	0.100
A2	1.050	-	1.150
b	0.300	-	0.400
c	0.100	-	0.200
D	2.820	-	3.020
E	1.500	-	1.700
E1	2.650	-	2.950
e	0.950 TYP		
e1	1.800	-	2.000
L	0.700REF		
L1	0.300	-	0.600
θ	0°	-	8°

15. Revision History

Version	Date	Page	Description
0.1	2007/01/19	-	New release
1.0	2007/03/22	All 3,4,7	Official release Add FS361B and FS361C products' ID