

## Phase Control Thyristor

$$V_{RRM} = 1200-1600 \text{ V}$$

$$I_{T(RMS)} = 75 \text{ A}$$

$$I_{T(AV)M} = 48 \text{ A}$$

$V_{RSM}$	$V_{RRM}$	Part Number
$V_{DSM}$	$V_{DRM}$	
V	V	
1300	1200	CS 60-12io1
1500	1400	CS 60-14io1
1700	1600	CS 60-16io1



PLUS247

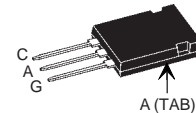

C = Cathode, A = Anode, G = Gate

Symbol	Test Conditions	Maximum Ratings
$I_{T(RMS)}$	$T_{VJ} = T_{VJM}$ (lead current limit)	75 A
$I_{T(AV)M}$	$T_C = 105^\circ\text{C}; 180^\circ \text{ sine}$	48 A
$I_{TSM}$	$T_{VJ} = 45^\circ\text{C}; V_R = 0 \text{ V}$	t = 10 ms (50 Hz), sine 1400 A t = 8.3 ms (60 Hz), sine 1500 A
	$T_{VJ} = T_{VJM}; V_R = 0 \text{ V}$	t = 10 ms (50 Hz), sine 1250 A t = 8.3 ms (60 Hz), sine 1340 A
$i^2t$	$T_{VJ} = 45^\circ\text{C}; V_R = 0 \text{ V}$	t = 10 ms (50 Hz), sine 9800 A <sup>2</sup> s t = 8.3 ms (60 Hz), sine 9500 A <sup>2</sup> s
	$T_{VJ} = T_{VJM}; V_R = 0 \text{ V}$	t = 10 ms (50 Hz), sine 7800 A <sup>2</sup> s t = 8.3 ms (60 Hz), sine 7500 A <sup>2</sup> s
$(di/dt)_{cr}$	$T_{VJ} = T_{VJM}; f = 50 \text{ Hz}; t_p = 200 \mu\text{s}; V_D = 2/3 V_{DRM}; I_G = 0.3 \text{ A}; di_G/dt = 0.3 \text{ A}/\mu\text{s}$	repetitive, $I_T = 60 \text{ A}$ 150 A/ $\mu\text{s}$
		non repetitive, $I_T = I_{T(AV)M}$ 500 A/ $\mu\text{s}$
$(dv/dt)_{cr}$	$T_{VJ} = T_{VJM}; R_{GK} = \infty; \text{method 1 (linear voltage rise)}$	$V_{DR} = 2/3 V_{DRM}$ 1000 V/ $\mu\text{s}$
$P_{GM}$	$T_{VJ} = T_{VJM}$	$t_p = 30 \mu\text{s}$ 10 W
	$I_T = I_{T(AV)M}$	$t_p = 300 \mu\text{s}$ 5 W
$P_{G(AV)}$		0.5 W
$V_{RGM}$		10 V
$T_{VJ}$		-40...+140 °C
$T_{VJM}$		140 °C
$T_{stg}$		-40...+125 °C
$F_C$	Mounting Force	20...120/4.5...27 N/lbs
Weight		6 g

### Features

- Thyristor for line frequency applications
- Junction coated, planar passivated die
- Long-term stability of blocking currents and voltages
- RoHS compliant
- Epoxy meets UL 94V-0
- International standard package

### Applications

- Motor control
- Power converter
- AC power controller
- Light and temperature controls

### Advantages

- Easy to mount
- Tab tin plated for surface mount
- Space and weight savings
- Simple mounting

Data according to IEC 60747

IXYS reserves the right to change limits, test conditions and dimensions

Symbol	Test Conditions	Characteristic Values	
$I_R, I_D$	$T_{VJ} = T_{VJM}; V_R = V_{RRM}; V_D = V_{DRM}$ $T_{VJ} = 25^\circ\text{C}$	$\leq 10$	mA
		$\leq 0.2$	mA
$V_T$	$I_T = 100 \text{ A}; T_{VJ} = 25^\circ\text{C}$	$\leq 1.4$	V
$V_{T0}$	For power-loss calculations only ( $T_{VJ} = 125^\circ\text{C}$ )	0.85	V
$r_T$		3.7	m $\Omega$
$V_{GT}$	$V_D = 6 \text{ V}; T_{VJ} = 25^\circ\text{C}$ $T_{VJ} = -40^\circ\text{C}$	$\leq 1.5$	V
		$\leq 1.6$	V
$I_{GT}$	$V_D = 6 \text{ V}; T_{VJ} = 25^\circ\text{C}$ $T_{VJ} = -40^\circ\text{C}$	$\leq 100$	mA
		$\leq 200$	mA
$V_{GD}$	$T_{VJ} = T_{VJM}; V_D = 2/3 V_{DRM}$	$\leq 0.2$	V
$I_{GD}$		$\leq 10$	mA
$I_L$	$T_{VJ} = 25^\circ\text{C}; t_p = 10 \mu\text{s}$ $I_G = 0.45 \text{ A}; di_G/dt = 0.45 \text{ A}/\mu\text{s}$	$\leq 450$	mA
$I_H$	$T_{VJ} = 25^\circ\text{C}; V_D = 6 \text{ V}; R_{GK} = \infty$	$\leq 200$	mA
$t_{gd}$	$T_{VJ} = 25^\circ\text{C}; V_D = 1/2 V_{DRM}$ $I_G = 0.45 \text{ A}; di_G/dt = 0.45 \text{ A}/\mu\text{s}$	$\leq 2$	$\mu\text{s}$
$R_{thJC}$	DC current	0.32	K/W
$R_{thJK}$	DC current	0.47	K/W

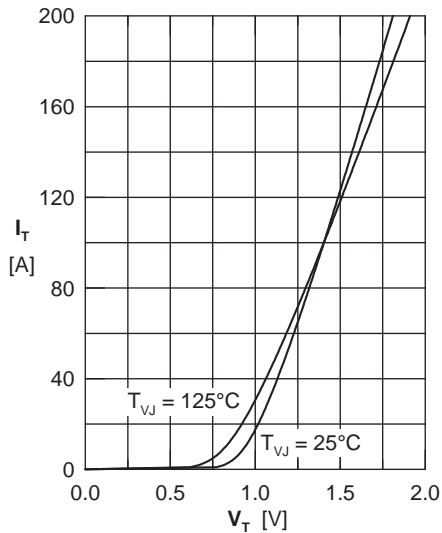
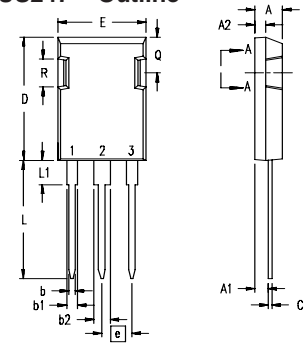

Fig. 1 Forward characteristics

### PLUS247™ Outline



Terminals: 1 - Cathode  
2 - Anode  
3 - Gate  
Tab - Anode

All leads and backside tab are tin plated.

Dim.	Millimeter		Inches	
	Min.	Max.	Min.	Max.
A	4.83	5.21	.190	.205
A <sub>1</sub>	2.29	2.54	.090	.100
A <sub>2</sub>	1.91	2.16	.075	.085
b	1.14	1.40	.045	.055
b <sub>1</sub>	1.91	2.13	.075	.084
b <sub>2</sub>	2.92	3.12	.115	.123
C	0.61	0.80	.024	.031
D	20.80	21.34	.819	.840
E	15.75	16.13	.620	.635
e	5.45 BSC		.215 BSC	
L	19.81	20.32	.780	.800
L1	3.81	4.32	.150	.170
Q	5.59	6.20	.220	0.244
R	4.32	4.83	.170	.190